

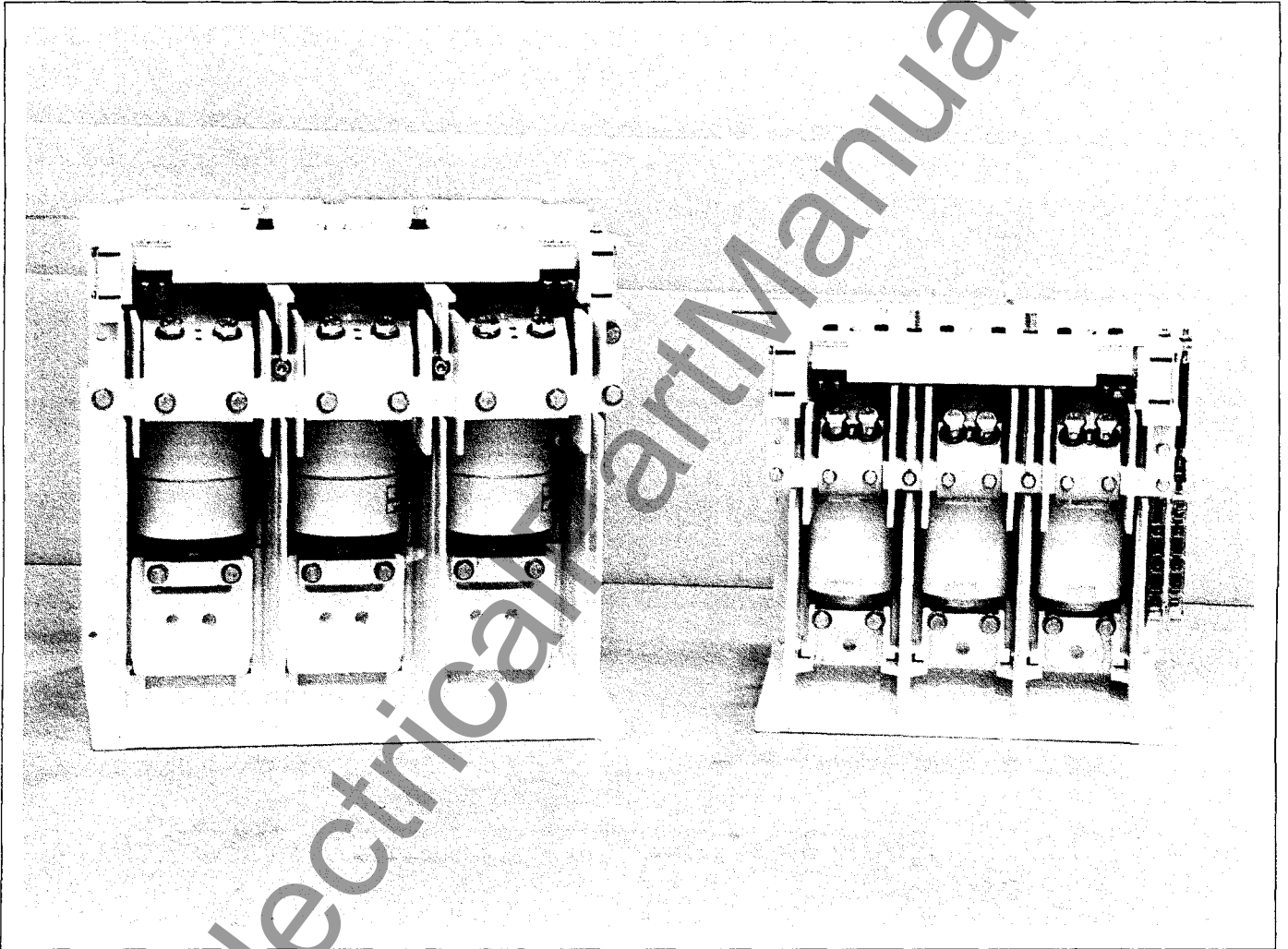

## GE CR193 Vacuum Limitamp™ Contactors





**Table of Contents**

**Section 1 – Introduction ..... 3**  
    General ..... 3

**Section 2 – Description ..... 3**  
    Principle of Operation ..... 3  
    Construction ..... 3

**Section 3 – Installation ..... 3**  
    General ..... 3

**Section 4 – Maintenance ..... 4**  
    General ..... 4  
    Inspection ..... 4

**Section 5 – Coil Adjustment and Replacement ..... 5**  
    Procedure for all Contactor Sizes ..... 5

**Section 6 – Contact Wear Check and Interrupter Reset ..... 6**  
    CR193B and CR193C Contactor Procedure ..... 6

**Section 7 – Interrupter Replacement ..... 7**  
    CR193B and CR193C Contactor Procedure ..... 7

**Section 8 – Auxiliary Interlock Adjustment & Replacement ..... 9**  
    Procedure for all Contactor Sizes ..... 9

**Section 9 – Vacuum Interrupter Integrity Test ..... 10**  
    General ..... 10

**Section 10 – Latch Mechanism ..... 11**  
    General ..... 11  
    CR193B and CR193C Contactor Adjustment Procedure ... 11

## SECTION 1 – Introduction

**Warning:** Before any adjustments, servicing, parts replacement or any other act is performed requiring physical contact with the electrical working components or wiring of this equipment, the power supply must be disconnected.

**Warning:** The vacuum interrupter integrity test (as described in section 9) should be performed before the high-voltage vacuum contactor is energized for the first time and each time the contactor is returned to service after maintenance, adjustment, or repair. Otherwise, this test should be performed annually.

Failure to perform this test may result in serious injury or death.

### General

These instructions cover vacuum Limitamp High-voltage Contactors. These contactors are designed for equipment used in starting ac motors with line voltages from 1000-Volts to a maximum of 7200-Volts, transformer feeders, and other high-voltage control equipment.

These contactors are designed to provide long, trouble-free service with only a minimal amount of maintenance.

These contactors can be identified by their catalog number. An outline of the catalog number nomenclature is shown in Table 1.

Table 1. Vacuum contactor catalog number system.

BASIC NUMBER: CR 193		1	2	3	4	5	6
1. CURRENT RATING:	A = 200A, 3.6KV B = 400A, 7.2KV C = 800A, 5.0KV						
2. COIL VOLTAGE:	000 = NO COIL 110 = 110/115 VDC OR RECTIFIED AC						
3. LATCH MECHANISM:	L0 = NO LATCH L1 = LATCH ELECTRICAL CLOSE AND OPEN L2 = LATCH ELECTRICAL CLOSE AND OPEN AND MANUAL OPEN						
4. NORMALLY OPEN (N.O.) AUXILIARY CONTACTS	00 = 0 N.O. CONTACTS 05 = 5 N.O. CONTACTS 10 = 10 N.O. CONTACTS 15 = 15 N.O. CONTACTS 20 = 20 N.O. CONTACTS SEE NOTE						
5. NORMALLY CLOSED (N.C.) AUXILIARY CONTACTS	00 = 0 N.C. CONTACTS 05 = 5 N.C. CONTACTS 10 = 10 N.C. CONTACTS 15 = 15 N.C. CONTACTS 20 = 20 N.C. CONTACTS SEE NOTE						
6. LATE OPENING NORMALLY CLOSED (L.O.N.C.) AUXILIARY CONTACTS	0 = 0 L.O.N.C. CONTACTS 1 = 1 L.O.N.C. CONTACTS 2 = 2 L.O.N.C. CONTACTS 3 = 3 L.O.N.C. CONTACTS 4 = 4 L.O.N.C. CONTACTS 5 = 5 L.O.N.C. CONTACTS SEE NOTE						

**Note:** Sum of N.O., N.C. and late opening normally closed (L.O.N.C.) interlocks cannot exceed 20. Interlock block assembly has 5 contacts/assembly. Maximum of four (4) block assemblies per contactor can be provided. Other combinations of NO., N.C., L.O.N.C. are possible. Change arguments to meet arrangement required.

## SECTION 2 – Description

### Principle of Operation

These contactors are magnetically operated by means of a dc coil. Energization of this coil causes the contacts inside the sealed vacuum interrupter to close and establish the power circuit. When this coil is de-energized two armature return springs force the moving armature to open the vacuum interrupter contact tips. As these tips open, the current in the power circuit is interrupted at the first current zero. This extremely quick interruption reduces the arc energy and results in low contact wear.

### Construction

The main components of these contactors are as follows: a one-piece, molded-glass, polyester case; a molded-glass, polyester moving armature; three vacuum interrupters; a coil and magnet; and a molded-glass, polyester terminal support bar.

These contactors can be fitted with up to twenty auxiliary contacts in any combination of normally open and normally closed. These contacts are housed in a clear, plastic housing for easy contact inspection.

Vacuum Limitamp Contactors are built with metric hardware, so that the contactor line can be used throughout the world.

## SECTION 3 – Installation

### General

All Vacuum Limitamp Contactors are subjected to thorough inspection and testing prior to packaging for shipment.

Observe the following precautions before applying power to a contactor for the first time.

1. Remove all packing materials that were used to protect the contactor in transit.
2. Carefully inspect all parts of the contactor for damage.
3. Remove any protective grease or oil which may be on the magnet pole faces, as the grease could collect dust and dirt, thus causing a sticking of the magnet.
4. Ensure that all parts of the contactor are clean. Accumulations of dust and dirt on high-voltage equipment can cause failures.
5. Manually operate the moving armature of the contactor to see that all parts operate freely.
6. Operate the contactor electrically under no load conditions by applying rated coil voltage to the coil terminals. Note that these contactors use dc operated coils. When the contactor has completely closed, the voltage applied to the coil must be reduced to approximately 25 percent of the rated voltage to prevent over-heating of the coil windings.
7. Perform a check on each vacuum interrupter as described in Section 9 entitled "Vacuum Interrupter Integrity Test."



## SECTION 4 – Maintenance

### General

Vacuum Limitamp Contactors will provide long trouble-free service if given the benefit of inspection, preventative maintenance, and periodic cleaning. The frequency of the inspection periods will depend upon the operating conditions for the contactor.

Table 2 below lists the adjustment tools and gages that are required to perform the inspection and adjustments as described in the following sections. See Figure 1.

**Table 2. Contactor Gages and Adjustment Tools**

TOOL DESCRIPTION	CR193B	CR193C
Contact Wear Gage	55A212185G1	55A212185G1
Interrupter Adjustment Wrench	55B532539P1	55B532548P1
Armature Setting Gage	55B532540P1	55B532547P1
Contacting Closing Tools <sup>ⓐ</sup>	55A212118G2	55A212118G2
Interlock Set Gage	55A212152P1	55A212152P1

<sup>ⓐ</sup>Quantity of two required.

Contactor gages and adjustment tools are available from the factory. Prices for the gages and tools are in GE Apparatus Handbook, Section 2072, page 4.

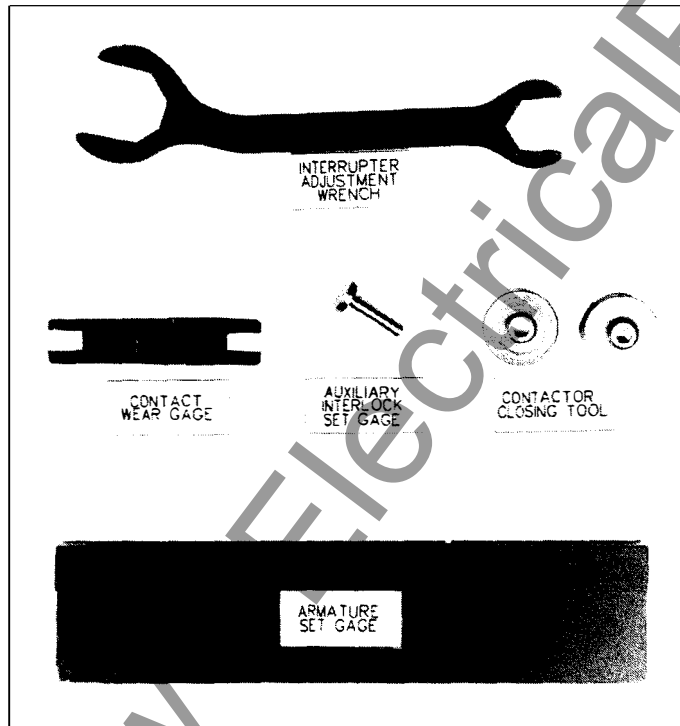

Figure 1. Tools for inspection and adjustment.

**Warning:** Disconnect the contactor from the power supply before making any inspections or adjustments as specified in sections 4 through 10.

**Caution:** Do not deviate from the instructions outlined. Do not force movement of the armature. Over-travel of the contacts beyond the limits specified could cause damage to the vacuum interrupter bellows. Do not twist the movable terminal of the interrupter. Rotational twisting can cause permanent damage to the interrupter bellows. Exercise care when replacing interrupters to prevent damage which can reduce the life of the equipment, and cause serious injury or death due to current leakage in the interrupter.

### Inspection

During routine inspections check for the following items.

1. Loose screws, nuts, and bolts.
2. Accumulation of dust or foreign material such as coal dust, cement dust, or lamp black. These materials must be periodically removed from the contactor if inspection shows any accumulation.

The outside surfaces of the vacuum interrupters must be wiped clean, as dust collects moisture which can cause a voltage breakdown around the outside of the interrupter.

3. Check the magnet and coil air gap setting. Refer to Section 5 "Coil Adjustment and Replacement".
4. Check each of the vacuum interrupters for contact wear. Refer to Section 6 "Contact Wear Check and Interrupter Reset".
5. Check auxiliary interlock adjustment and contact wear. Refer to Section 8 "Auxiliary Interlock Adjustment and Replacement".
6. Perform a check on each vacuum interrupter as outlined in Section 9 "Vacuum Interrupter Integrity Test".
7. Check the contactor latch mechanism if applicable. Refer to Section 10 "Latch Mechanism".

**SECTION 5 – Coil Adjustment and Replacement  
Procedure for all Contactor Sizes.**

1. If the contactor has no latch proceed directly to Step 2.
2. If the contactor is fitted with a latch, disconnect the unlatch coil control wires and remove the two (2) latch mounting screws and lift the latch mechanism from the contactor.
2. If the contactor coil requires replacement due to overheating or other damage follow Steps 3 through 11. If the coil does not need replacement follow Steps 9 through 11.
3. Disconnect coil terminal wires. See Figure 2.
4. Remove the three (3) coil mounting screws. See Figure 2.
5. Lift coil assembly out of contactor. See Figure 3.
6. Position the new coil into the contactor and start the three (3) mounting screws. Do not fully tighten these screws at this time.

7. Close contactor manually using the contactor closing tools. See Item A, Figure 6. Ensure that the pole faces of the coil mate with the moving armature.
8. Tighten the three (3) coil mounting screws fully. Open contactor by removing closing tools.
9. With the contactor in the open position check the magnet and coil air gap using the armature setting gage. Insert the gage fully between the armature and the coil pole faces. The gage should be a close sliding fit. See Figure 4. If adjustment is necessary follow Steps 10 and 11. If adjustment is not required then no other checks of the coil are necessary. Proceed directly to step 11.
10. Remove the two (2) barrel nuts at top of push-off spring rods (See Figure 4, Item C) and adjust the two (2) plastic stop nuts until the close sliding fit is obtained at the gage. Reassemble the two (2) barrel nuts and tighten them against the plastic stop nuts.
11. If the contactor is fitted with a latch mechanism, reassemble the latch and adjust as discussed in Section 10 "Latch Mechanism".

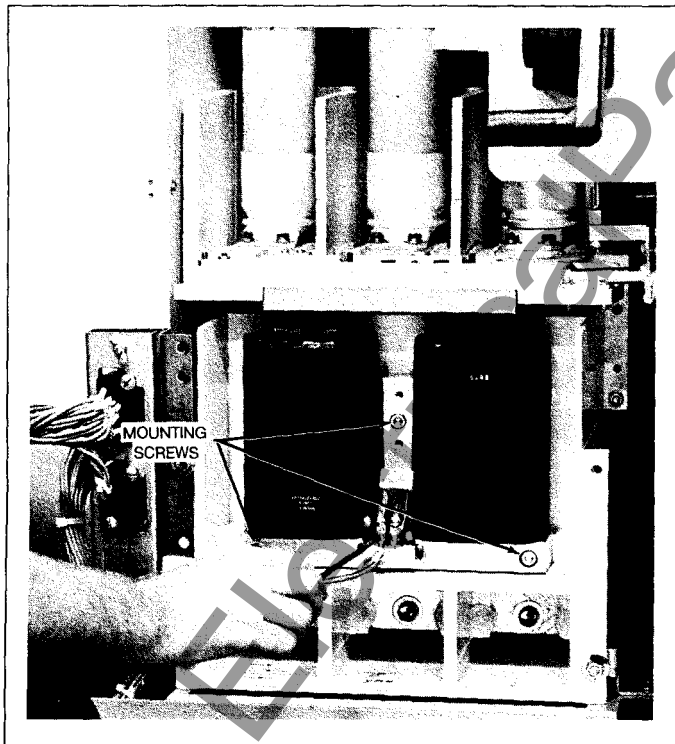

Figure 2. Coil terminal wires and mounting screws.

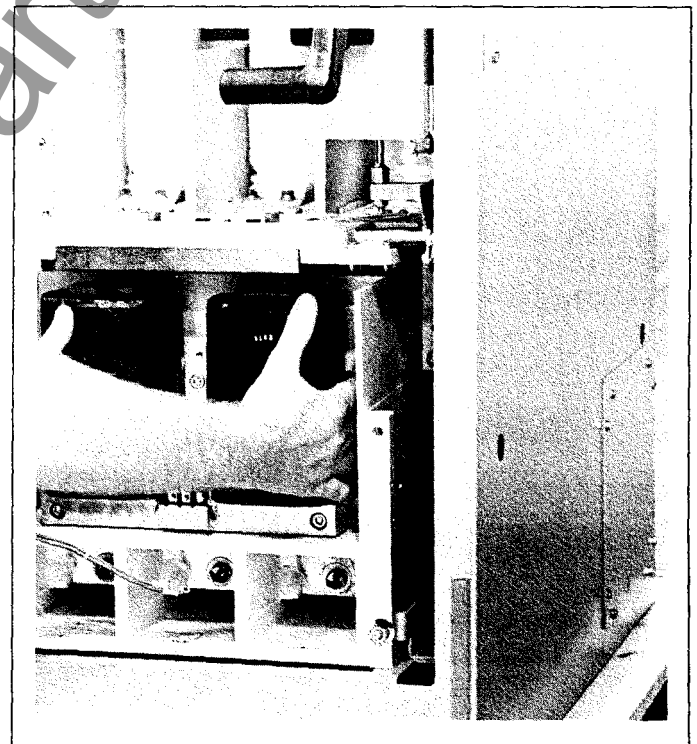

Figure 3. Removal of coil assembly.

WWW



## SECTION 5 – Coil Adjustment and Replacement

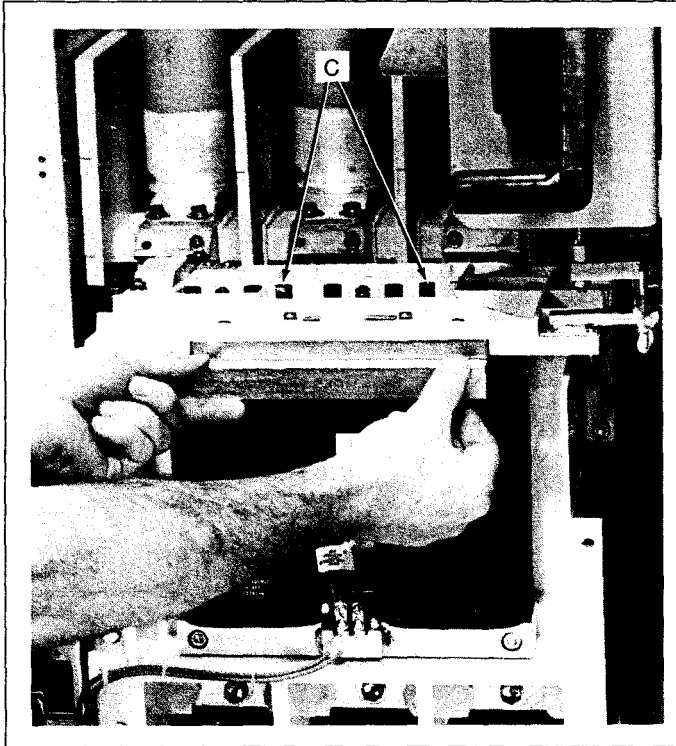

Figure 4. Insertion of armature setting gage.

## SECTION 6 – Contact Wear Check and Interrupter Reset

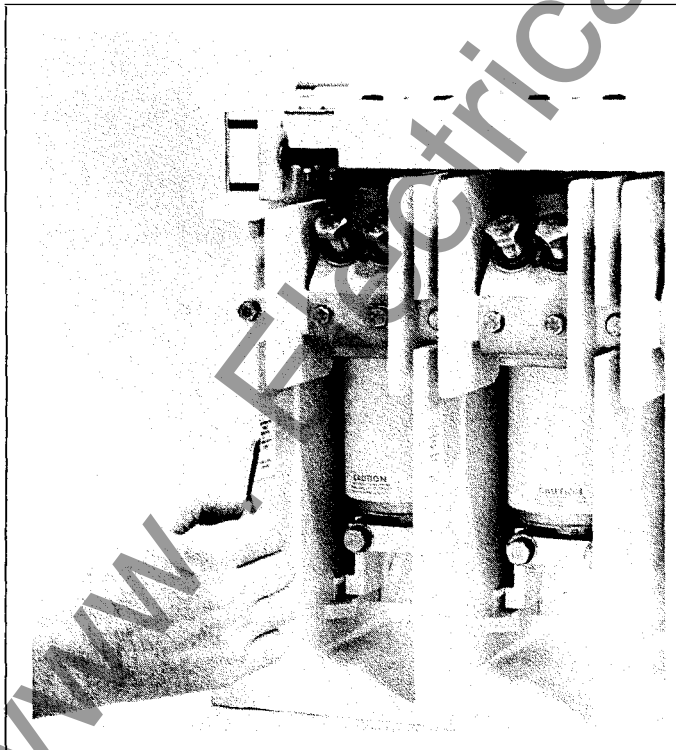

Figure 5. Appropriate removal of peel-off label.

## CR193B (400-Ampere) and CR193C (800-Ampere) Contactor Procedure

1. Close the contactor using the contactor closing tools (Item A, Figure 6). Do not overtighten. A single sheet of ordinary paper inserted between the armature and closing coil may be used as a helpful feeler gage to determine when the armature has just closed against the face of the coil poles.
2. Check for contact wear by inserting the “RESET” end of the contact wear gage between the locknuts and the spacer sleeve as shown in Figure 6. If the “RESET” end of the gage CANNOT be inserted then the interrupter needs to be reset. Follow Steps 3 through 7. If reset is not required go to Step 7. Each interrupter should be checked and reset as required.
3. Loosen the two (2) clamp block screws (Item D, Figure 7) until the interrupter alignment ball is free to rotate.
4. Using the interrupter adjustment wrench turn the alignment ball to raise the interrupter until the “INITIAL” end of the gage can be inserted as shown in Figure 6.
5. Retighten the two (2) clamp block screws (8 lb-ft.) to lock the alignment ball in place. After the clamp block screws are tightened check to see that the fit at the wear gage is tight; if not re-adjust the interrupter position as described in Step 4.
6. Adjacent to the interrupter is an interrupter reset indicator label. This label indicates the number of times each interrupter has been reset. Remove the appropriate portion of the peel-off label. See Figure 5. If the interrupter has previously been reset two (2) times then the indicator label will show blue and red marking in the areas where the peel-off portions of the label have been removed during previous resets. If this is the case the interrupter must be replaced. Refer to Section 7 “Interrupter Replacement”.
7. Remove the contact wear gage and the contactor closing tools.

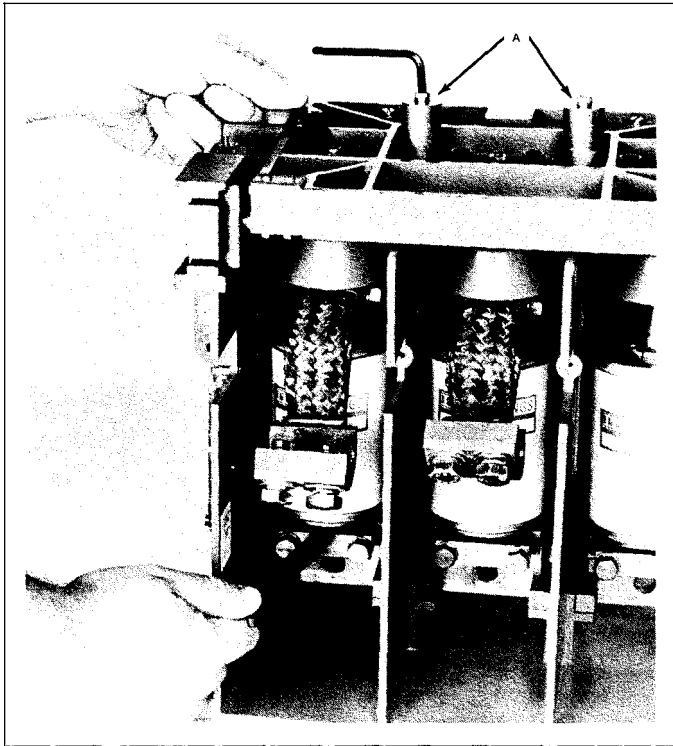

Figure 6. Checking contact wear with wear gage.

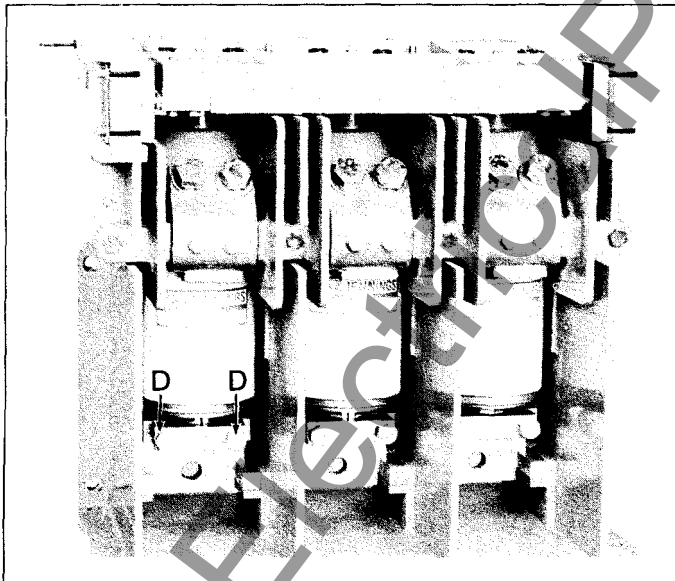

Figure 7. Loosening the clamp block screws.

## SECTION 7 – Interrupter Replacement

### CR193B (400-Ampere) and CR193C (800-Ampere) Contactor Procedure

The procedures below describe the steps required to replace a single interrupter. Repeat steps for each interrupter that requires replacement.

1. Remove the two (2) nuts and the spacer sleeve from the top of the interrupter driver stem. Items A and B, Figure 9.
2. Remove the six (6) screws which attach the flexible braid assemblies to the terminal support bar. Item C, Figure 10.
3. Remove the four (4) screws that attach the terminal support bar to the contact box. Item D, Figure 10. Lift the terminal support bar out of the contact box.
4. Remove the two (2) clamp block screws and the clamp block from the bottom of the interrupter assembly. Items E and F, Figure 10.
5. Withdraw the interrupter assembly downwards from the contactor. See Figure 11.
6. Remove the alignment ball, contact pressure spring, and guide bearing (Items G, H, and I, Figure 12) from the interrupter. Assemble parts on new interrupter assembly.
7. Insert new interrupter assembly into the contactor. Make sure that the brass guide bearing on the interrupter is fully-seated in the spherical bearing on the contactor moving armature.
8. Reassemble the spacer sleeve and one nut to the top of the interrupter driver stem. With the contactor in the open position adjust the nut on the driver stem until the top of the driver stem is level with the top of the bearing support. See Figure 8. Assemble the second nut to the driver stem and lock it against the first nut.

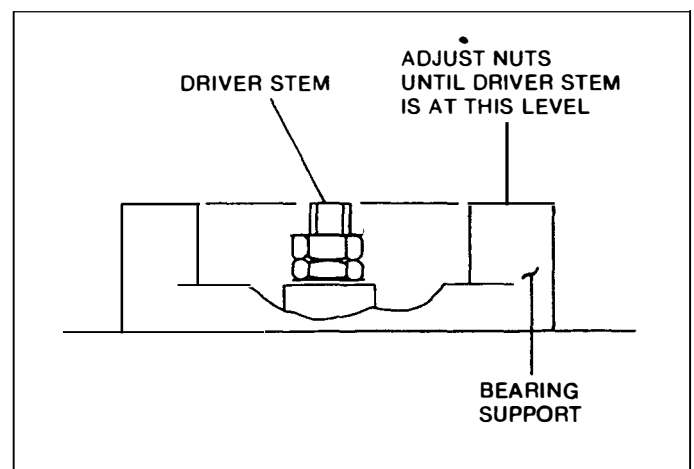

Figure 8. Interrupter reassembly.

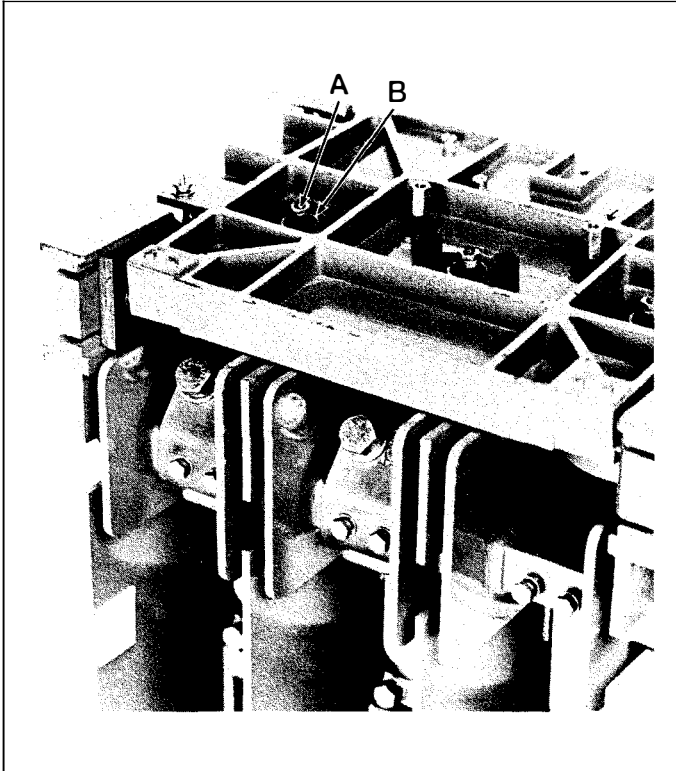

Figure 9. Removal of the nuts and spacer sleeve from interrupter driver stem.

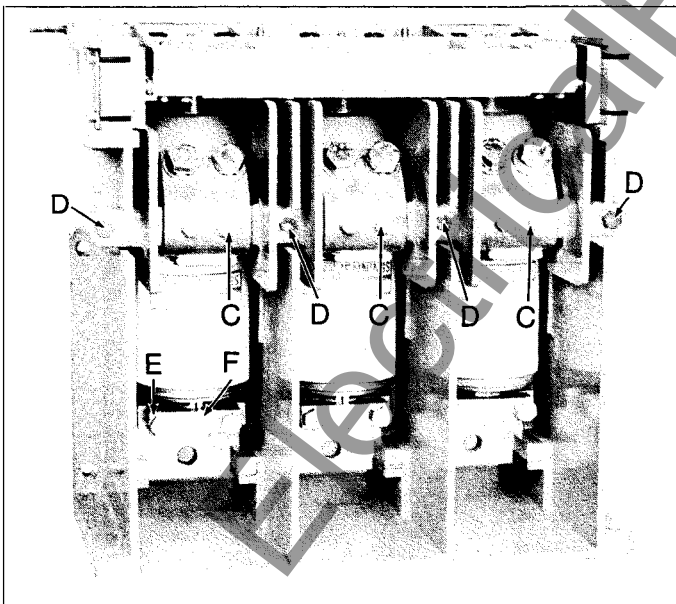

Figure 10. Removal of screws attaching the flexible braid assemblies with the terminal support bar.

## SECTION 7 – Interrupter Replacement

9. Manually close the contactor using the contactor closing tools. Do not overtighten. A single sheet of ordinary paper inserted between the armature and closing coil may be used as a helpful feeler gage to determine when the armature has just closed against the face of the coil poles.

10. Reassemble the clamp block and the clamp block screws over the alignment ball. Make sure the alignment ball is fully seated in the clamp block. Do not fully tighten the clamp block screws at this time.

11. Using the interrupter adjustment wrench to turn the alignment ball, raise or lower the interrupter until the "INITIAL" end of the contact wear gage can be inserted between the spacer sleeve and the nuts on the driver stem. See Figure 6.

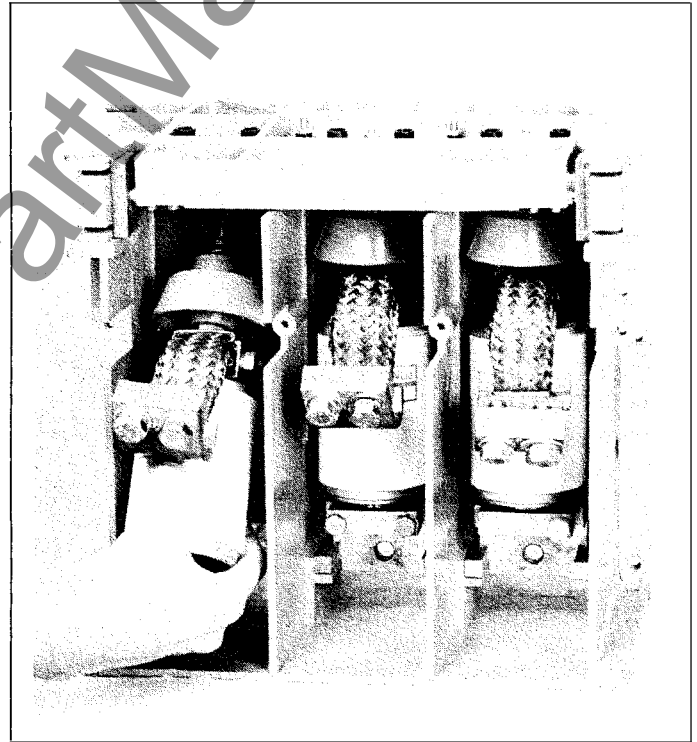

Figure 11. Downward removal of interrupter assembly.



12. Tighten the two (2) clamp block screws (8 lb-ft.) to lock the alignment ball in place. After the clamp block screws are tightened check to see that the fit at the wear gage is tight; if not re-adjust the interrupter position as discussed in Step 11.

13. Remove the old interrupter reset indicator label that is adjacent to the interrupter and apply new label supplied. See Figure 5.

14. Reassemble the terminal support bar to the contact box and attach each of the flexible braid assemblies to the support bar.

15. Remove the contact wear gage and contactor closing tools.



Figure 12. Interrupter alignment ball, contact pressure spring and guide bearing.

## SECTION 8 – Auxiliary Interlock Adjustment and Replacement

### Procedure for All Contactor Sizes

The procedures below describe the steps required to replace an interlock block assembly. Interlock blocks should be replaced when the following conditions exist:

- The contacts are badly pitted or burned.
- The contact tips are worn to a point where the silver facing on the tips has worn by 0.02 inches.

**NOTE:** Tarnish on the silver facings does not have to be removed because the tarnish breaks down into products that are conductive when power is applied.

1. Tag all the wires that connect to the interlock terminals and then remove. See Figure 13.
2. Remove the nut from top of interlock driver stem on the top side of the armature molding (or extension arm). Item A, Figure 13.

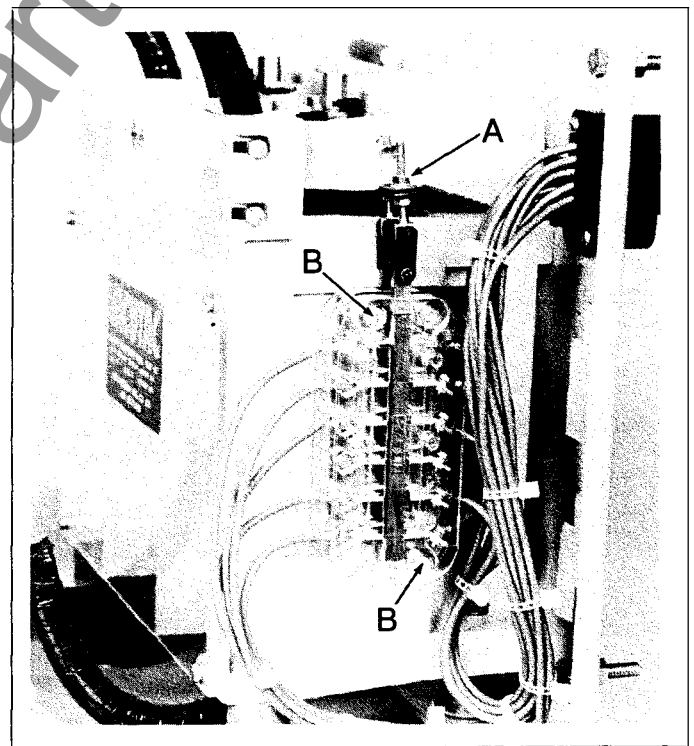

Figure 13. Replacement of interlock block assembly.



## SECTION 8

3. Remove the two (2) interlock mounting screws and remove the interlock from the contactor. Item B, Figure 13. Remove any extension rods, nuts, and washers that might be connected to the interlock and assemble these parts to the new interlock assembly.
4. Assemble the new interlock assembly to the contactor using its two (2) mounting screws. Install the nut on the top of the interlock driver stem but do not tighten at this time.
5. Insert the interlock set gage into the bottom of the interlock as shown in Figure 14.
6. Adjust the nuts at the armature molding (extension arm) until the moving contact carrier inside the interlock block just touches the top of the interlock set gage. See Figure 14.
7. Tighten the nuts on both the top and bottom sides of the armature molding (or extension arm). Make sure that the interlock clevis and contact carrier are not twisted as the nuts are tightened.
8. Reattach all wire to their appropriate terminal.

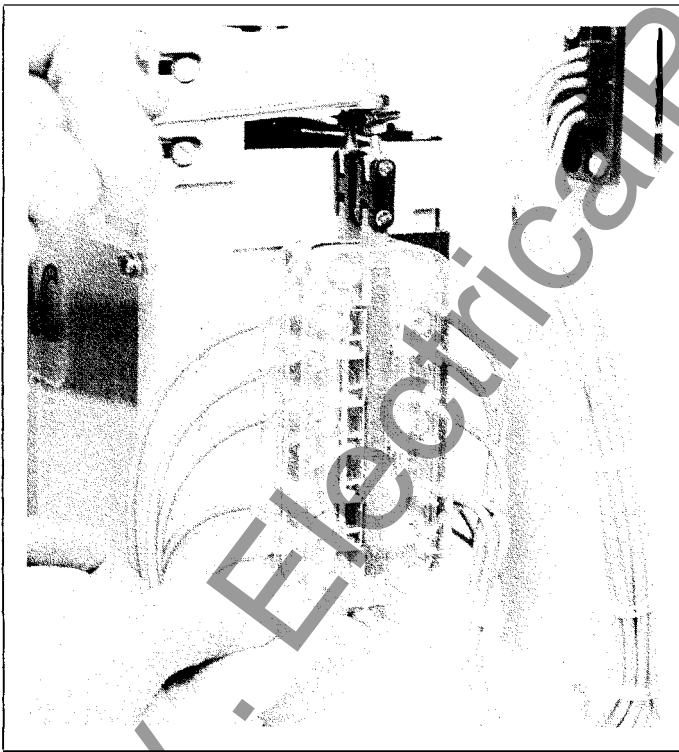

Figure 14. New interlock adjustment.

## SECTION 9 – Vacuum Interrupter Integrity Test

**Caution:** X-Ray emissions may be produced if an abnormally high voltage is applied across the open contacts of a vacuum interrupter. Do not apply a voltage that is higher than the values recommended in the test instructions.

### General

This test determines the internal dielectric condition and vacuum integrity of the vacuum interrupters. Prior to performing this test the outside of the vacuum interrupters should be wiped clean of any contaminants with a non-linting cloth or industrial type wiper. During this test each vacuum interrupter should be checked individually.

**Warning:** The vacuum interrupter integrity test should be performed before the high voltage vacuum contactor is energized for the first time, and each time it is returned to service after maintenance, adjustment, or repair. Otherwise, this test should be performed annually.

**Caution** should be exercised during this test since high-voltage testing is potentially hazardous.

Failure to perform the vacuum interrupter integrity test may cause serious injury or death.

High-potential test instruments can be purchased to perform the vacuum interrupter integrity test. The following is a recommended test instrument:

Hipotronics Model 7BT60A

Use of a DC Hipot is not recommended because results may indicate a problem with a good interrupter. If you wish to use a DC Hipot, set at 28kV, but if interrupter fails, confirm failed interrupter using above AC Hipot.

**Warning:** Caution should be exercised during this test since high-voltage testing is potentially hazardous.

**Note:** Before performing vacuum integrity test, confirm that both the armature gap setting (Section 5) and contact wear adjustment (Section 6) are proper.

1. With the contactor in the open position connect the test leads to the contactor power terminals as shown in Figure 15. Apply 20-kV rms, 60-Hertz power for 400 ampere and 800 ampere contactors, and hold for a minimum of five seconds.
2. Reverse the leads and repeat the test.
3. If no breakdown occurs the interrupter is in an acceptable condition. If a breakdown occurs, the interrupter should be replaced. Refer to Section 7 “Interrupter Replacement”.

*Note: No attempt should be made to try to compare the condition of one vacuum interrupter with another nor to correlate the condition of any interrupter to low values of DC leakage current. There is no significant correlation.*

4. After the HIGH POTENTIAL VOLTAGE is removed from the interrupters the metal end caps of the interrupters should be discharged with a grounding rod to remove any residual electrical charge.

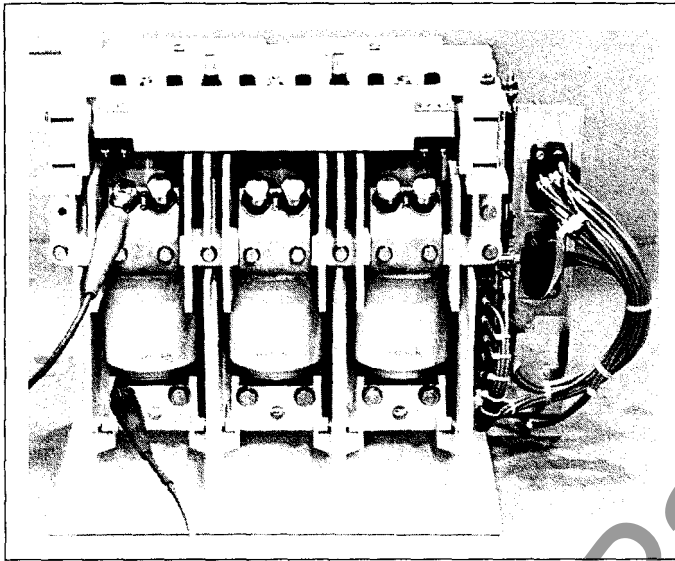

Figure 15. Testing the vacuum interrupter.

## SECTION 10 – Latch Mechanism

### General

The mechanical latch mechanisms that are used on Vacuum Limitamp Contactors are mounted directly to the contactors.

The purpose of the latch is to hold the contactor closed without the need for continuous coil power. The contactor can be closed (latched) by energizing the main contactor closing coil. Once the contactor is latched the power to the main closing coil should be removed to prevent coil overheating. To open (unlatch) the contactor, power is applied to the unlatch coil on the latch mechanism. Once the contactor is open the power to the unlatch coil should be removed to prevent coil overheating.

The latch mechanism can also be unlatched manually by operating the manual release mechanism if a contactor with the "L2" latch option is specified.

### CR193B (400-Ampere) and CR193C (800-Ampere) Contactor Adjustment Procedure

1. Steps 2 through 4 describe the steps necessary to mount the latch mechanism to the contactor. If the latch mechanism is already assembled on the contactor, proceed directly to Step 5 for adjustment procedure for the latch.

2. Mount the latch mechanism to the contactor using the two (2) latch-mounting screws supplied. The latch mounts directly to the center mounting post of the contactor coil. The latch-mounting plate is provided with a clearance hole for the center-mounting screw on the contactor coil.

3. Assemble the catch (see Figure 16) to the contactor moving armature using one each 0.010", 0.030" and 0.060" shims and the hardware provided.

4. Connect the control wires to the unlatch coil terminal block on the side of the latch mechanism support bracket (see Figure 16).

5. Close the contactor electrically and allow to latch closed. Note that both the main closing coil and the unlatch coil have to be deenergized after operation to prevent coil overheating. With main coil deenergized, measure gap between centerline of contactor moving armature and the main coil pole faces. Desired range for this separation between pole faces is 0.009" to 0.013". If outside this range, manually unlatch contactor, then add or remove shims as required to meet desired range (see Figure 16) and repeat measurement.

6. With contactor still latched closed, energize main coil. Set nut and release knob (see Figure 16) so that dimension "X" is equal to 0.060" +/- 0.005". Deenergized main coil.

7. Manually operate the latch by pulling the release knob. The latch mechanism should move freely and the contactor should move to the fully open position.

8. Electrically operate the latch and unlatch coils to insure that these operate properly.

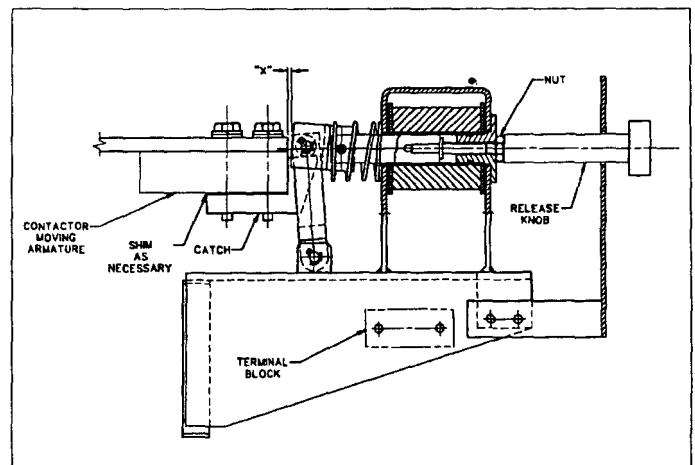

Figure 16. Cross-sectional view of CR193B and CR193C latch.

These instructions do not purport to cover all details or variations in equipment nor to provide for every possible contingency to be met in connection with installation operation or maintenance. Should further information be desired or should particular problems arise which are not covered sufficiently for the purchaser's purposes, the matter should be referred to the GE Company.



**GE Electrical Distribution & Control**

General Electric Company  
P.O. Box 489, 6801 Industrial Dr., Mebane, N.C. 27302



GEF-8016A RENEWAL PARTS BULLETIN

**CR193B, C & D<sup>®</sup>**  
**Vacuum Limitamp<sup>®</sup> Contactors**

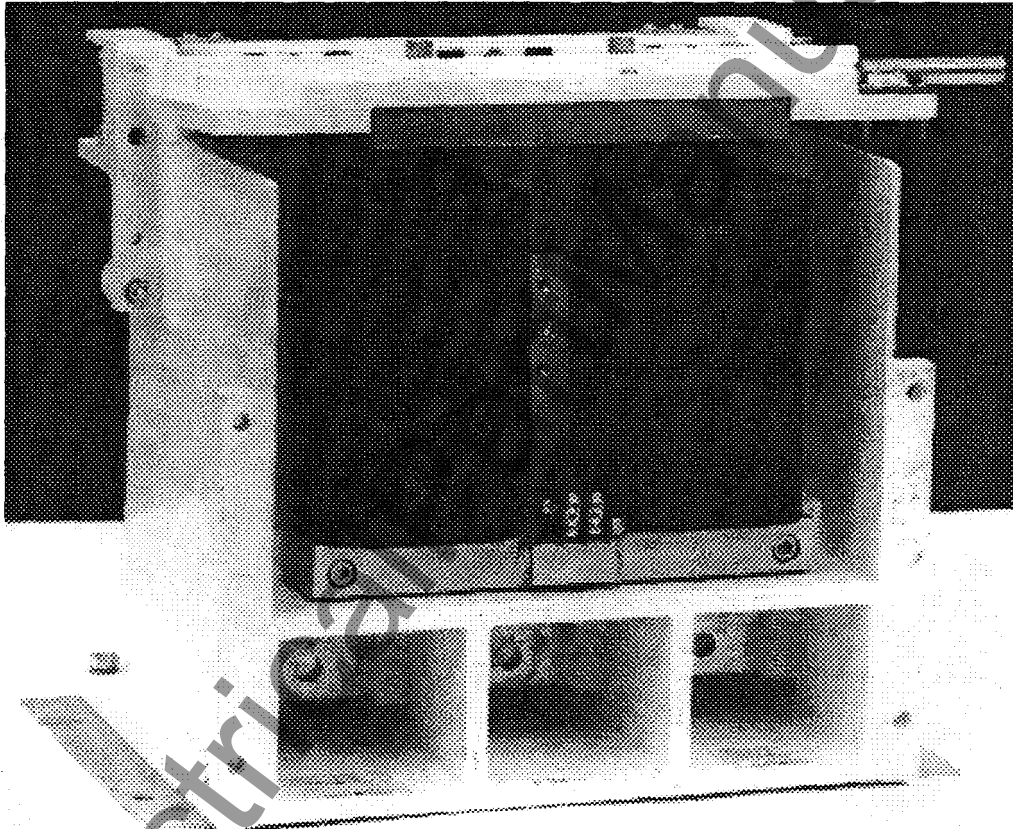

---

<b>Table Of Contents</b>	<b>Page</b>
General information .....	3
400 and 800 Amp Contactors .....	4
Wire Harnesses .....	5
Coil Assemblies .....	5
Vacuum Bottle Assemblies .....	5
Guide Assemblies .....	5
Top Assemblies .....	6
Adjustment Tool Kits .....	6
Mechanical Latch .....	6
Auxiliary Interlocks .....	7
Bottle Guide Assemblies.....	8
Bottom Terminal Assemblies.....	8
Drawout Contactor Parts .....	8

These instructions do not purport to cover all details or variations in equipment for every possible contingency to be met in connection with installation, operation, or maintenance. Should further information be desired or should particular problems arise which are not covered sufficiently for the Purchaser's purposes, the matter should be referred to the nearest GE Sales Office.

## General Information

This renewal parts bulletin will provide the proper identification of standard parts which may be required for the maintenance of CR193B & D (400A) and CR193C (800A) Vacuum Limitamp contactors.

Both the complete contactors and required renewal parts are shown as catalog numbers and are supported by photographs.

Catalog numbers identified in this bulletin may not be the same as those parts on the original equipment. The renewal part catalog numbers are shown in kit form.

It is the intent of this bulletin to give our customers a quick and accurate way to identify parts required for normal maintenance of the Vacuum Limitamp contactors. Unless otherwise stated, all of the parts shown in the bulletin are compatible with the contactors manufactured since 1985.

Attention should be given to forecasting your particular renewal parts requirements to ensure on-site availability of the specific parts as required for normal maintenance and proper operation of your equipment.

To maintain maximum operating efficiency and reliability of your equipment, genuine GE renewal parts are recommended.

Since contactors are supplied to meet specific customer control and distribution requirements, certain replacement parts not listed in this publication may occasionally be required. Please refer to the factory for these requests.

In these situations, please provide a complete description of the part, along with the complete data shown on the contactor nameplate that is affixed to the top of the contactor.

For pricing and availability of parts shown in this bulletin, contact your nearest GE sales office.

400A and 800A Vacuum Contactor

Fig. 1

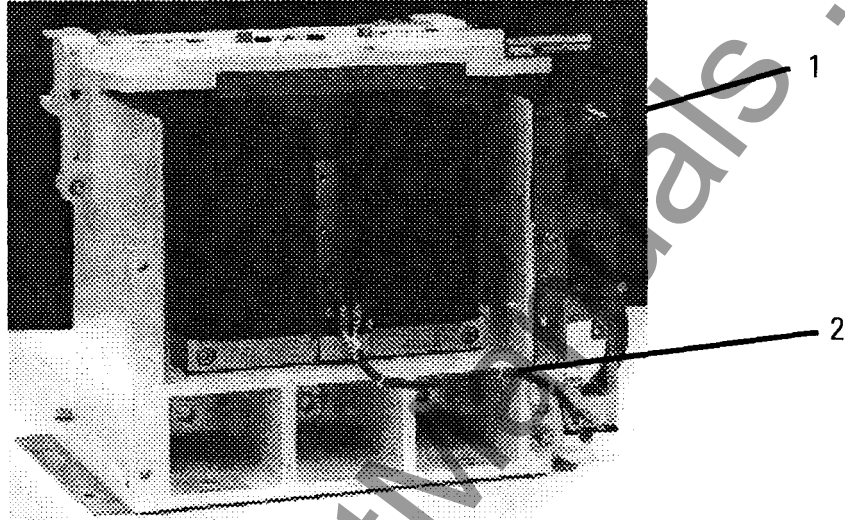

Contactors can be identified by their catalog number, located on the nameplate on the top of the contactor.

Note: 400A contactor shown in photo

400 Amp Contactor

800 Amp Contactor

CR193B & D Vacuum contactors are designed for equipment used in starting AC motors with line voltages from 1000-Volts to a maximum of 7200-Volts, transformer feeders, and other medium voltage control equipment.

CR193C Vacuum contactors are designed for equipment used in starting AC motors with line voltages from 1000-Volts to a maximum of 5000-Volts, transformer feeders, and other medium voltage control equipment.

Item	Description	Part Number
1	Contactors Bracket and Pin Assembly	55B533223G4
2	Control Wire Harness	See Fig. 2
3	Plug Bracket and Socket Assembly (not shown)	55B533224G4

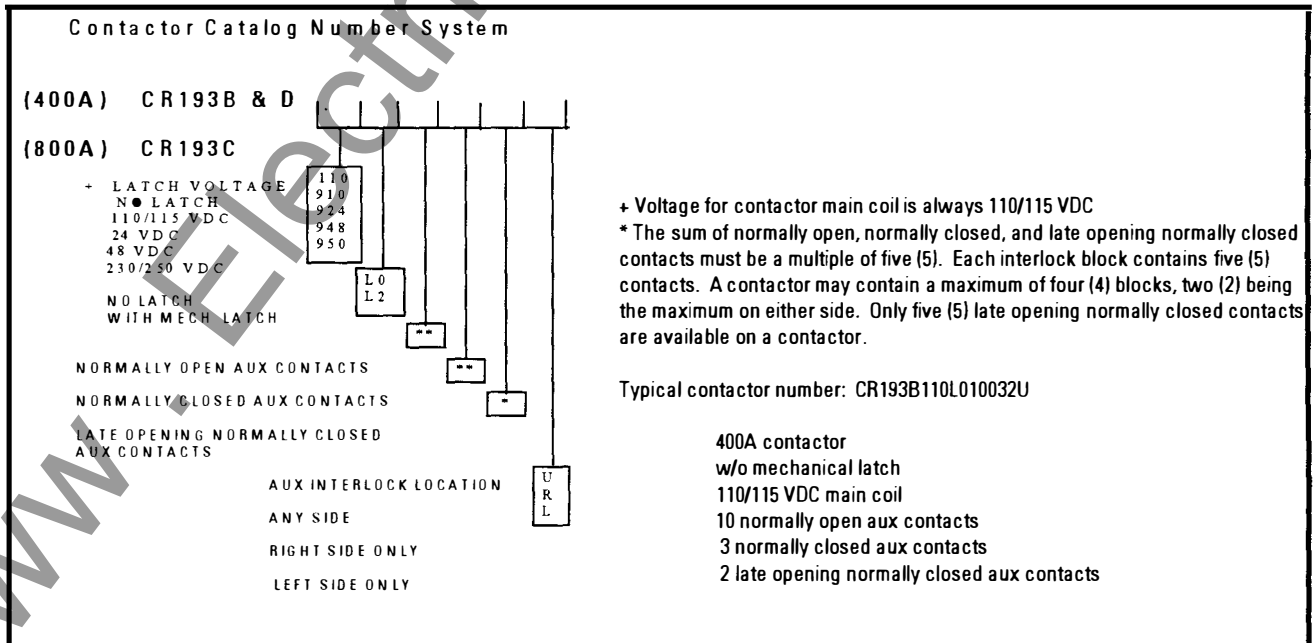
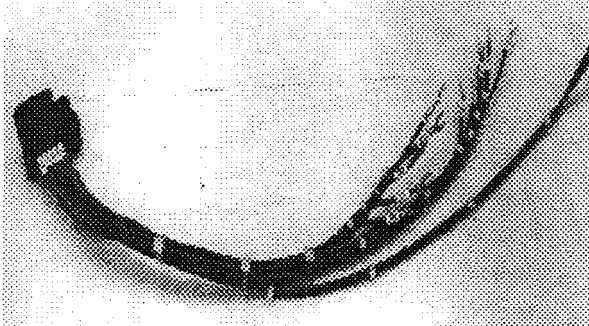



Fig. 2



**Wire Harness Assembly**

Description	Part Number
Single Block Harness	VCP1
Double Block Harness	VCP2
Triple Block Harness	VCP3
Four Block Harness	VCP4

Note:  
Single block harness shown in photo

Fig. 3

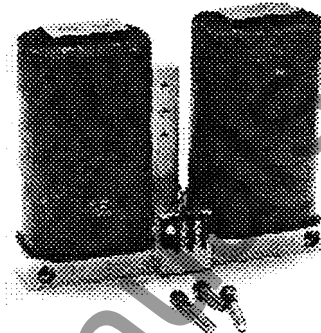

**Coil Assembly**

Description	Part Number
CR193B & D, 400 amp contactor	55D781008G3R
CR193C, 800 amp contactor	55D781014G3R

Note:  
400A coil shown in photo

Fig. 4

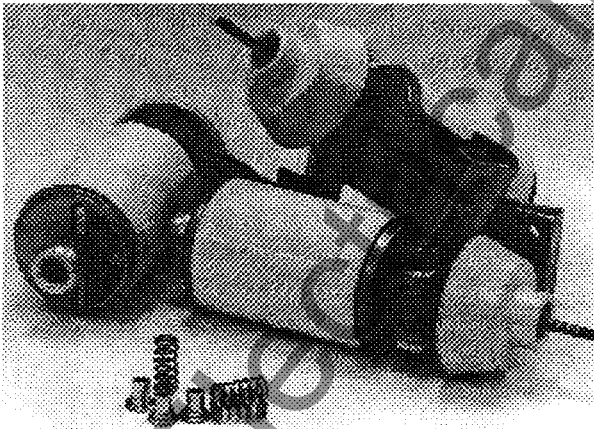

**Vacuum Bottle Assembly**

Description	Part Number
CR193B & D, 400 amp contactor	55C679806G1RP
CR193C, 800 amp contactor	55C679810G1RP

Note:  
Above part numbers include three (3) vacuum bottles and necessary hardware.  
400A contactor parts shown in photo

Fig. 5

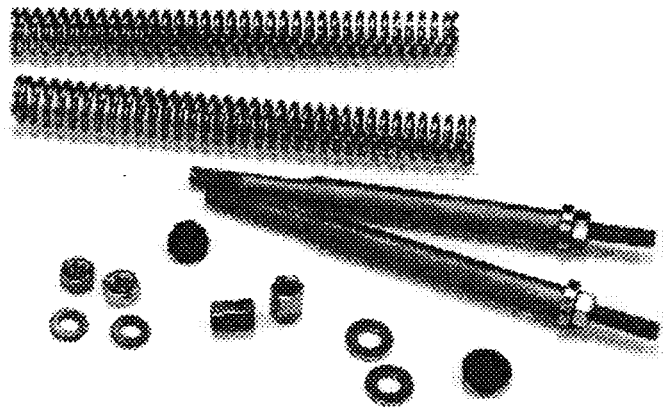

**Guide Assembly**

Description	Part Number
CR193B & D, 400 amp contactor	55D781008G2R
CR193C, 800 amp contactor	55D781014G2R

Note:  
400A contactor guide parts shown in photo

Fig. 6

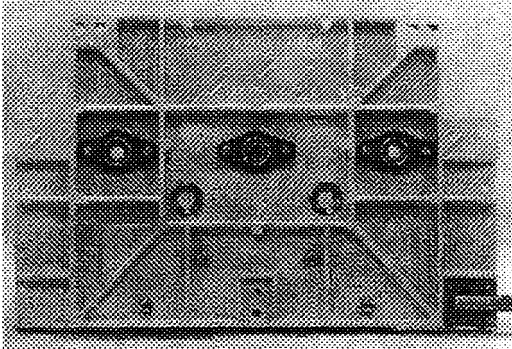

**Contactor Top Assembly**

Description	Part Number
CR193B & D, 400 amp contactor	55D781008G1R
CR193C, 800 amp contactor	55D781014G1R

Note:  
400A top assembly shown in photo

Fig. 7

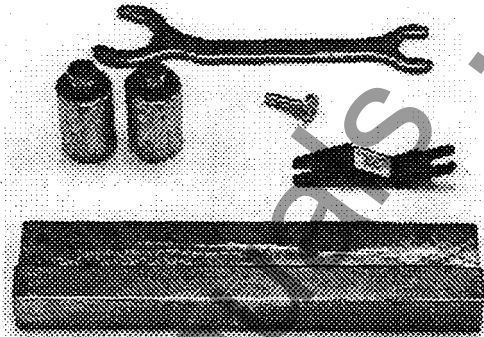

**Contactor Adjustment Tool Kit**

Description	Part Number
CR193B & D, 400 amp contactor	302A3900DCG1
CR193C, 800 amp contactor	302A3900DCG2

Note:  
400A tool kit shown in photo

Fig. 8

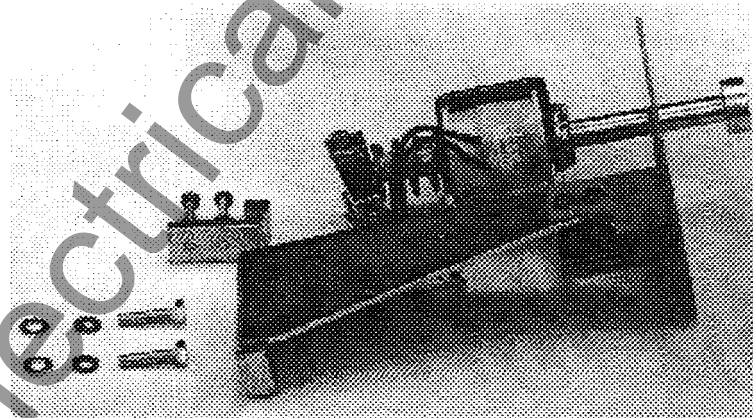

**Mechanical Latch Assembly**

Description	Part Number
110/115 VDC	55C679819G3RA
24 VDC	55C679819G3RB
48 VDC	55C679819G3RC
230/250 VDC	55C679819G3RD

Fig. 9

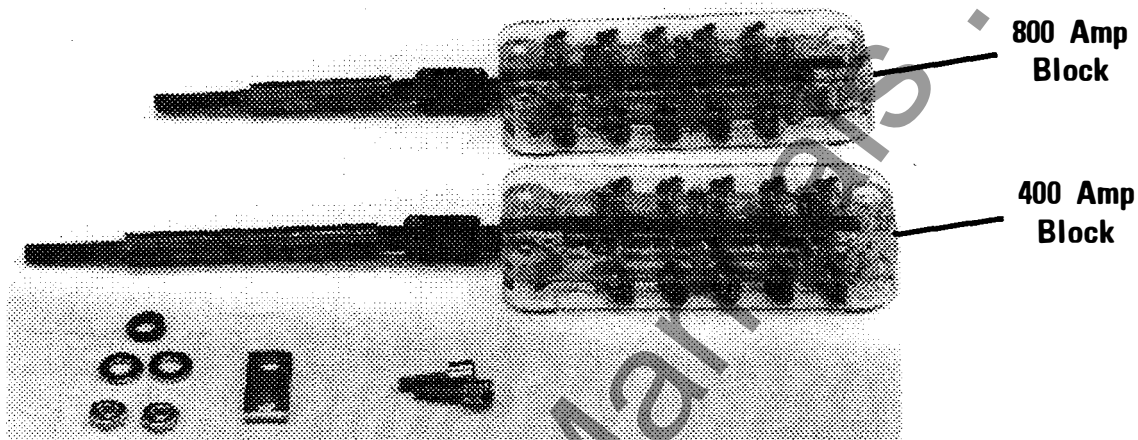

**Auxiliary Interlocks**

The table below lists all possible combinations of auxiliary interlocks within a single block. Select the contact arrangement desired and add the suffix letters to the appropriate part number (i.e., 55C679809G2RP).

<u>Contactor</u>	<u>Part Number</u>
CR193B & D, 400 Amp contactor	55C679809
CR193C, 800 Amp contactor	55C679814

Suffix	NO	NC	LONC
G1RP	5		
G2RP	4	1	
G3RP	3	2	
G4RP	2	3	
G5RP	1	4	
G6RP		5	
G7RP	4		1
G8RP	3	1	1
G9RP	2	2	1
G10RP	1	3	1
G11RP		4	1

Suffix	NO	NC	LONC
G12RP	3		2
G13RP	2	1	2
G14RP	1	2	2
G15RP		3	2
G16RP	2		3
G17RP	1	1	3
G18RP		2	3
G19RP	1		4
G20RP		1	4
G21RP			5

Note:  
 NO = Normally open contacts  
 NC = Normally closed contacts  
 LONC = Late opening normally closed contacts

Fig. 10

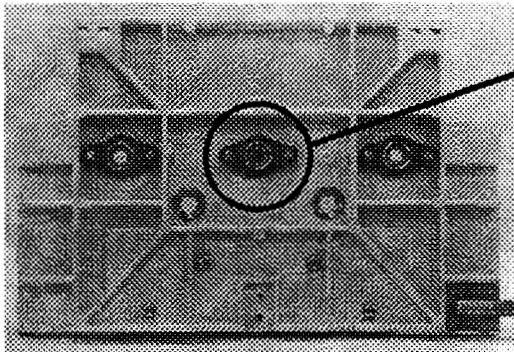

Bottle Guide

Bottle Guide Assembly

Fig. 11

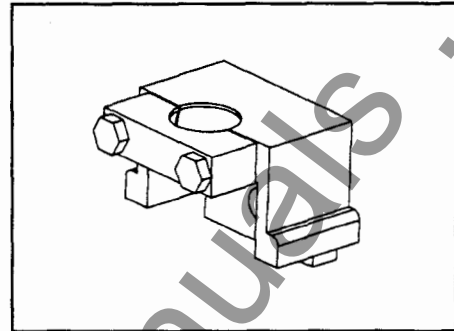

Bottom Terminal Assembly

Description  
 CR193B & D, 400A contactor  
 CR193C, 800 A contactor

Part Number  
 55D781011G1R  
 55D781017G1R

Note:  
 400A top assembly shown in photo

Description  
 CR193B, 400A contactor  
 CR193D, 400A drawout contactor  
 CR193C, 800A contactor

Part Number  
 55D781008G4R  
 55D781008G5R  
 55D781014G4R

Note:  
 400A terminal parts shown in photo

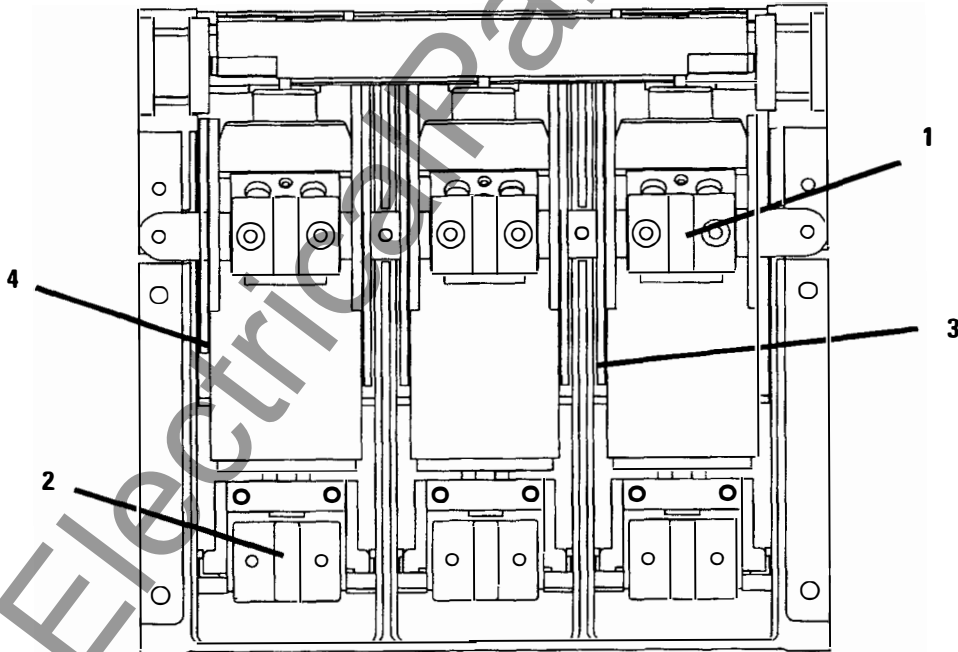

Fig. 12

**Drawout Contactor (CR193D) Parts**

<u>Item</u>	<u>Description</u>	<u>Part Number</u>	<u>Quantity</u>
1	Line Side Stab "T" Block	55B532562P3	3
2	Load Side Stab "T" Block	55B532562P2	3
3	Phase Divider	55C679821P2	2
4	Phase Barrier	55C679821P3	1

Note: Item #2 must be used with with correct bottom terminal per Fig. 11

( Blank Page )



GEF-8016A 0795

General Electric Company  
P.O. Box 489, 6801 Industrial Dr. , Mebane, N.C. 27302

*GE Electrical Distribution & Control*

www.ElectricalPartManuals.com