

Controllers With
Draw-out Contactors

GEF-4630



Limitamp[®] Control

CR7160 Renewal Parts Bulletin

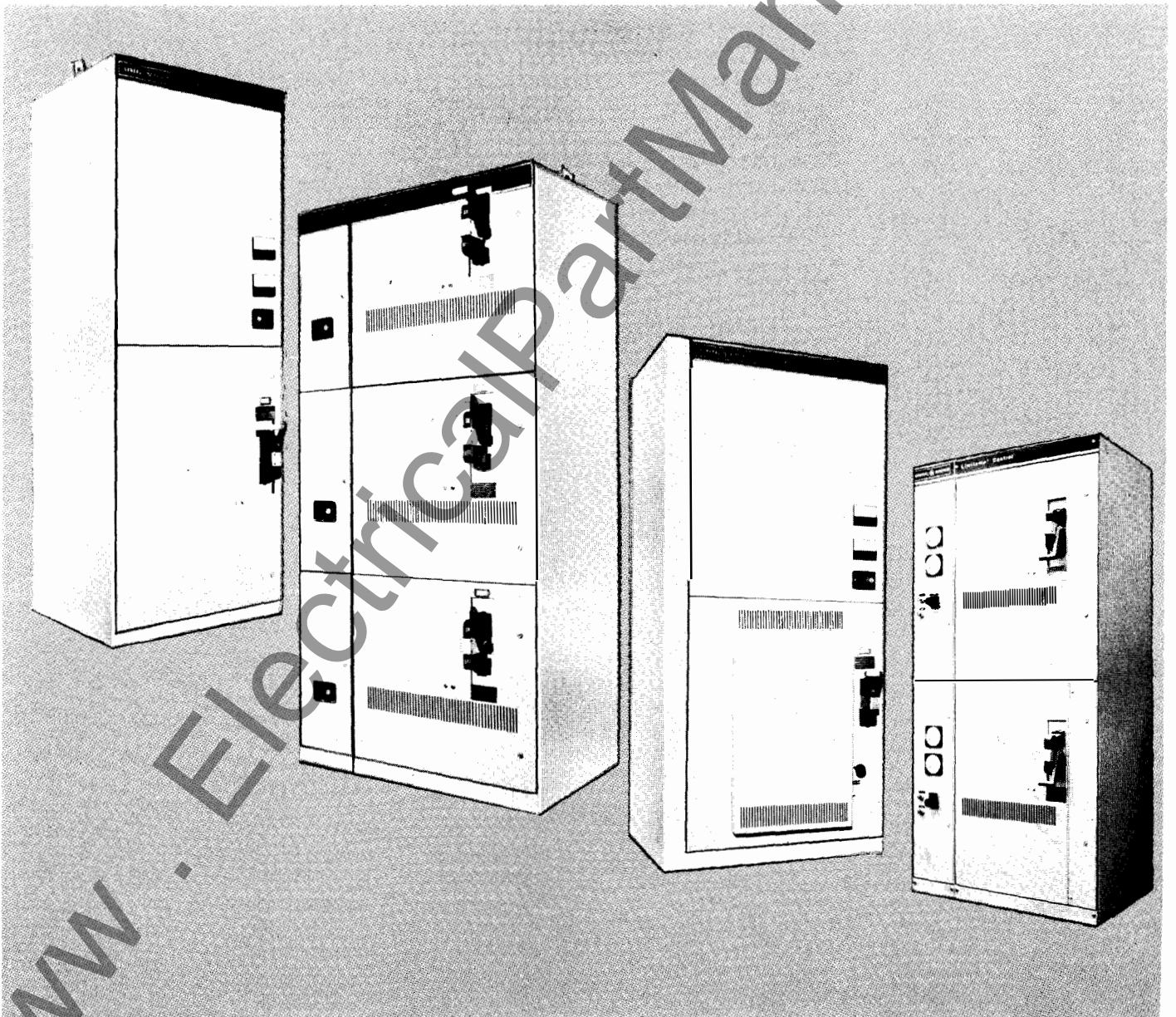

GENERAL  ELECTRIC

Table Of Contents

Introduction	3
Parts Identification	3
Limitamp® Panel Data Nameplate	3
High Voltage Contactor Nameplate	3
Catalog Numbering	4
One-high Construction	4, 5
Two-high Construction	6, 7
Three-high Construction	8, 9
Isolating Mechanism (Handle)	10
Vertical Bus Assemblies	10, 11, 12
Stab & Track Assemblies	12, 13, 14
Fuse Support Assemblies (Control Power Transformer)	15

Introduction

The CR7160 Limitamp® Controller, a quality product of the General Electric Company, was designed and manufactured to give long and satisfactory service. This bulletin contains items which, through normal use, may require periodic replacement; other items may never need service or replacement during the useful life of the equipment.

You are in the best position to determine your investment in Renewal Parts, taking into consideration the total amount of Limitamp Control in your facility, your proximity to General Electric

franchised distributors, and the importance of minimizing equipment downtime.

Reference Publications

GEH-3091; Instructions for Air-break Controllers
 GEH-3102; Instructions for Contactor
 GET-3140; Application Data

Parts Identification

This bulletin will provide the information necessary to identify, by description or actual catalog number, replacement parts for Limitamp Motor Controllers.

The following pages will describe where important equipment identification numbers can be found, and provide catalog numbers for assemblies and individual parts which may require periodic replacement though normal wear.

Should a situation arise where a part cannot be identified, the factory should be contacted. In order for the factory to provide assistance in identifying the part, the *Catalog Number* and *Diagram Number* of the equipment *Must Be Known* (see *Limitamp Panel Data Nameplate*).

High Voltage Contactor Nameplate

High voltage contactor renewal parts are found in separate renewal parts publications depending on the contactor catalog number. This catalog number is found on the contactor nameplate mounted on the steel bracket directly above the contactor coil. An example of this nameplate is shown below:

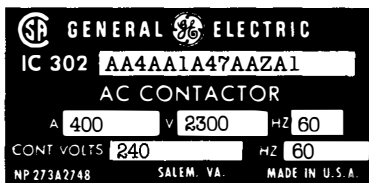

The proper bulletin can be selected from the table below:

Contactor Catalog Number	Renewal Parts Publication
IC302A	GEF-4551
IC302B	GEF-4573
IC302C	GEF-4574
IC302D	GEF-4575
IC302E	GEF-4576
IC2814	Refer to Factory

Limitamp Panel Data Nameplate

This nameplate is mounted near the starter handle operator on the high voltage door. It contains all the necessary information for the factory to positively identify the starter and its bill of material. This information must accompany all part orders and quotation requests. Below is an example of the nameplate:

GENERAL ELECTRIC

LIMITAMP PANEL DATA

MODEL 7160A118G CAT 0424X0399R01 A01

DIAGRAM 221B3456

● POWER FUSE CAT. NO. 218A4291P6RB ●

LOAD: _____

4000 V, 60 HZ, 3 PH

MTR SEC. _____ V, _____ A

FIELD _____ V DC, _____ A, 0.8 PF

CONTROL 115 V, _____ HZ

INTERRUPTING RATING 350 MVA, CLASS E 2

CAUTION BEFORE INSTALLING OR OPERATING READ INST. GEH-3091, GEH-3102

DO NOT OPERATE STARTERS FURNISHED WITH CURRENT TRANSFORMERS UNLESS RELAY ELEMENTS ARE INSTALLED.

259A8798P2 MEBANE, N.C. MADE IN U.S.A.

The required information is the catalog number and the diagram number. The catalog number from the sample above is **0424X0399R01 A01**. The number can be broken down as follows: **0424X0399** is the material list number or shop order number for the job; **R01** is the overall lineup designation; and **A01** is a section in that lineup. The diagram number identifies the group of drawings that pertain to this particular project order. See page 4 for the "CR" designations.

Sections that do not have a panel data nameplate will have a compartment nameplate mounted on the right side door flange. An example is shown below:

FOR LIMITAMP® CONTROLLER

CAT. 0424X0399R01 S B01

N.P. 161868

This will provide the catalog number only. The diagram number can be obtained from any *Panel Data Nameplate* on that lineup.

Catalog Numbering System

Limitamp control is manufactured basically in three types of construction: one-high; two-high; and three-high. One-high construction consists of *one* medium voltage contactor in one ninety-inch high enclosure. Two-high construction contains *two* medium voltage contactors in one ninety-inch high enclosure and in Three-high construction, there are *three* medium voltage contactors in one ninety-inch high enclosure.

You should first determine the type construction (one-high, two-high, or three-high) of your equipment. After determination, the following pages should be consulted:

- Pages 4 and 5 to be used for one-high construction only.
- Pages 6 and 7 to be used for two-high construction only.
- Pages 8 and 9 to be used for three-high construction only.

Caution should be observed in that a part number in one-high construction may have a different description and catalog number than the same part number in two- or three-high construction.

A further means of identifying construction is by means of the controller "CR" number (shown on the panel data nameplate on page 3). Example: Catalog Number 7160A118G. The alpha suffix determines one-high, two-high, or three-high; G is one-high; K is two-high; H is three-high.

This "CR" number is further referenced in GEH-3091C, page 4.

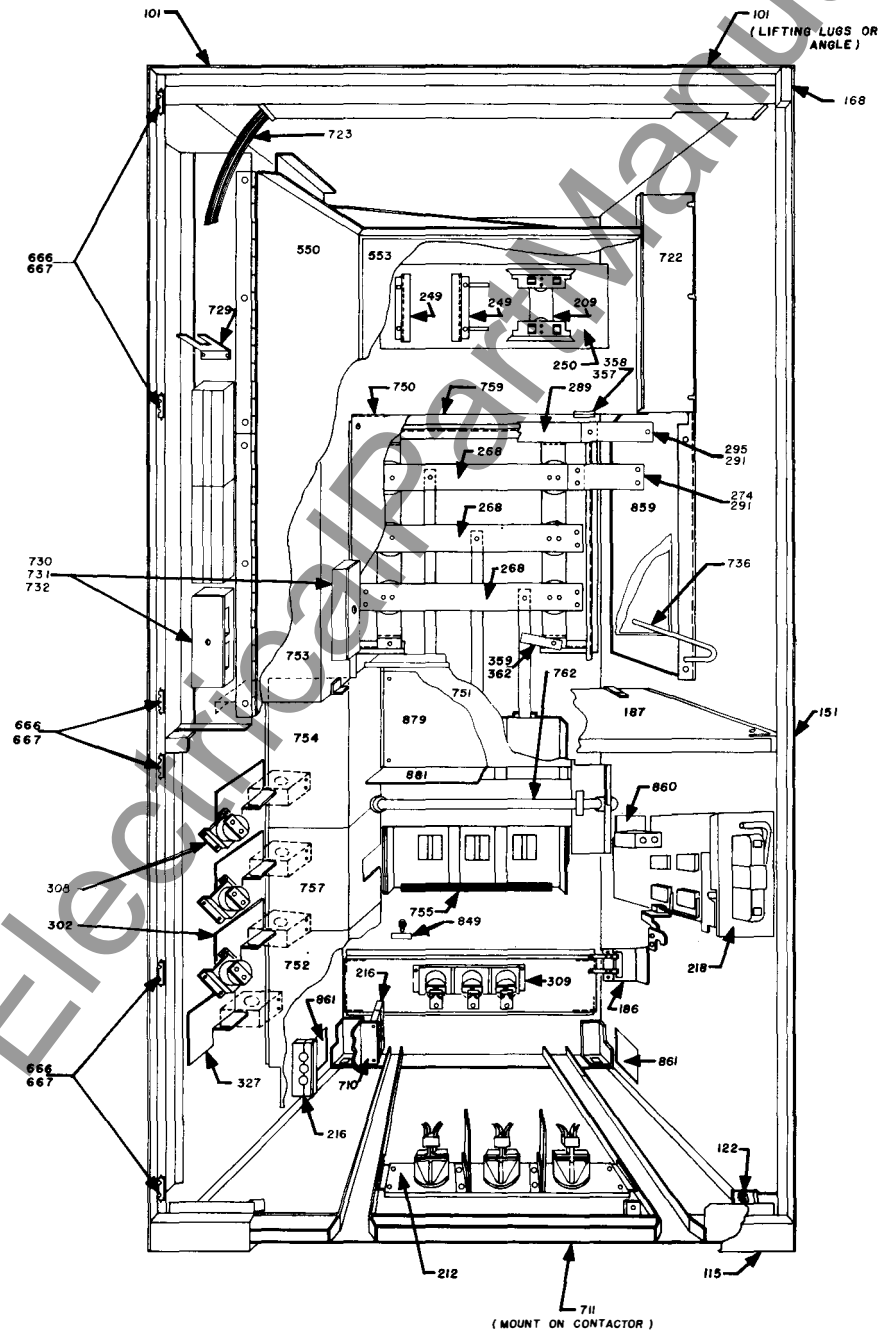

One-high Construction

One-high Parts List①

Mtl. List Part No.	Part Name Description	Typical Catalog Number (Variable)	Qty.
101	Lifting Lugs	288A593P1	02
115	Lintel	68J210552AM34XXXXB	01
112	Lintel Catch	194A7164G1	01
151	Shell Asm	68J210550ADXXXXXB	01
168	Gasket Asm NEMA 1	117B4557G1	01
168	Gasket Asm NEMA 1A, 3, 12	118B7100G2	01
186	Coil Stab Asm LV	194A6909G1	01
187	Compartment Barrier Asm	149B1774G1	01
194	Defeater Latch Asm	194A6916G1	01
209	Fuse Supt Asm	104B9352G②	01
212	Interm. Stab Asm	194B1743G③	01
216	Mot. Cble Clamp Asm	245A1863AAG4	02
218	Handle Asm	116C9928G1④	01
249	CPT Mounting Feet	117B4525P7	02
250	CPT Mounting Base	68J210552AB34XXXXB	01
268	AC Bus Copper	104B9369P1N	03
268	AC Bus Alum	148B5102P1N	03
274	AC Splice Copper	193A7666P1	03
274	AC Splice Alum	193A7666P3	03
289	Ground Bus	104B9334P1N	01
289	Ground Bus Alum	104B9334P10N	01
291	Hardware Asm Lineup/Bus	218A6390G1	01
295	Ground Bus Splice Copper	104B9334P	01
295	Ground Bus Splice Alum	104B9334P11	01
302	CT Supt	219A1229P1	03
308	Dummy CT Sup Asm	394B686G1	01
309	Motor Stab Asm	149B1743G⑤	01
326	GCT Supt	219A1229P1	01
357	Cable Bush. 1.75 Fem	167A8405P5	01
358	Cable Bush. 1.75 Male	161A8674P5	01
359	CPT Cable Clamp	104B9335P5	08
362	CPT Cable Clamp Supt	205A5761P1	02
550	Swingout Panel	68J210552AAXXXXXB	01
553	LV Base	68J120132BT0504AAB	01
653	LV Door	68J22 B	01
656	HV Door	68J210551AAXXXXXB	01
657	Hdl Instr Label	232A6987P1	01
659	Door Latch Asm	104B9336G2	03
666	Door Hinge Pin	1459941P1	06
667	Door Hinge	147A4728G1	06
710	Mot Cable Barrier	174A8930P1	01
711	Cont Bolt Instr NP	194A4472P1	01
722	Swing Base Stop-Barrier	68J120125DL0000AAB	01
723	Wire Harness	711850G1	01
729	Wire Plug Supt	219A1225P1	01
730	Wire Comb Cleat	171B4725P1	03
731	Wire Comb Cover	171B4726P1	03
732	Wire Comb Supt	219A1242P1	01
736	Swingout Handle	104B9332P6	01
750	AC Bus Barrier (Inc Line)	149B1753G1	01
751	Ver Bus Barrier Asm	149B1753G4	01
752	Low Inc Line Barr Bot	194A6985G1	01
753	Upr Inc Line Barr	68J210553AHXXXXXB	01
754	Low Inc Line Barr Upr	68J120125MF0000AAB	01
755	Ver Bus Barr Bot Cover	194A6968P2	01
757	Low Inc Line Barr Ctr	68J120125MG0000AAB	01

Mtl. List Part No.	Part Name Description	Typical Catalog Number (Variable)	Qty.
759	AC Bus Bar Upper Shelf	68J210553AJXXXXXB	01
762	Shutter-Bus Asm	194A4480G⑥	01
809	Panel Data NP	259A8798P1	01
812	Comp. Ident. NP	NP161868	01
815	Publicity NP	157C8115P2	01
849	Grd Stud NP	194A6999P2	01
859	Bus Cover Plate	68J120125BM0000AAB	02
861	Cable Cover Plate	194A7197P5	01
862	Intlk Cover Plate	194A7183P3	02
879	P/T Base	68J120131AL0000AAB	01
881	P/T Insulator	205A4475P2	01

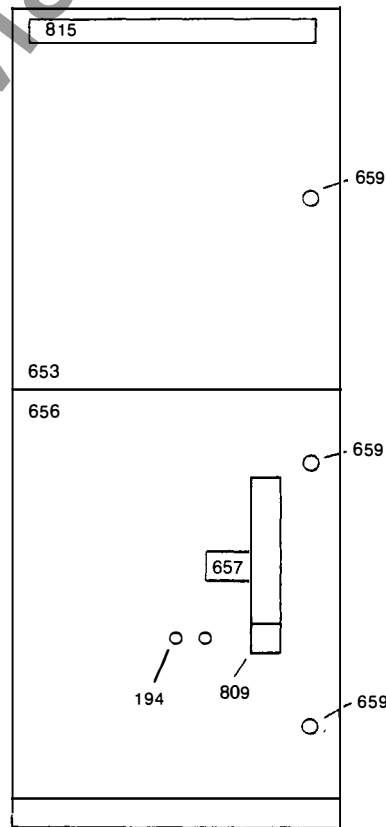

Doors and related parts only

① Catalog numbers in list are for only (1) combination. See req'n Material List for actual list.
 ② See page 15.
 ③ Refer to page 13 for complete catalog number.
 ④ See page 10.
 ⑤ See page 11.
 ⑥ See page 10.

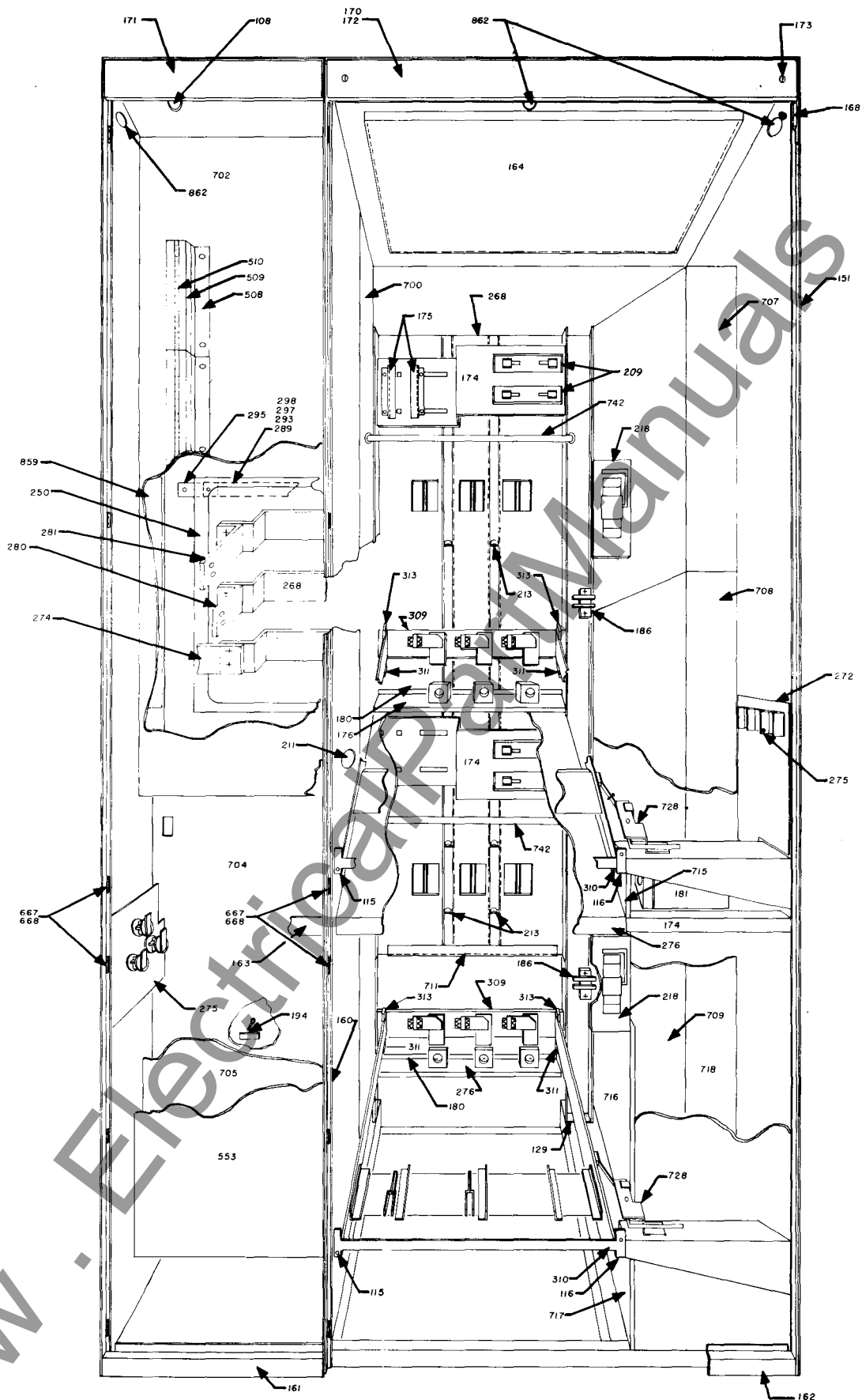

Two-high Construction

Two-high Parts List ①

Mtl List Part No.	Part Name Description	Typical Catalog Number (Variable)	Qty.
108	Plug Button	N529P63B6	01
111	Publicity NP	194B6315P2	01
115	Left Track Sup	139B8564G3	01
116	Right Track Sup	139B8564G4	01
129	Washer Plate	194A7383P1	06
151	Shell Asm	68J210550BL449030B	01
160	Vertical Lintel	68J220134FD0000AAB	01
161	Bot LV Lintel	149B3258P1	01
162	Bot HV Lintel	68J120134JD0000AAB	01
163	LV Mullion	174A8913G1	01
164	Dust Shield	68J120125EU0000AAB	01
168	Gasket NEMA 1	117B4557G1	01
168	Gasket NEMA 1A, 3, 12	118B7100G2	01
170	Wire Trough	68J220134FU0000AB	01
171	Top LV Lintel	233A1836G1	01
172	Top HV Lintel	68J120134FR0000AAB	01
173	Lintel Latch Screw Asm	174A7367G1	02
174	RH Center Mullion	259A1447G1	01
174	CPT Fuse Base Asm	68J220134FH0000AAB	01
175	CPT Clamp Brackets	233A1841P2	02
176	CT. Supt. Asm	177B2069G1	01
180	CT Barrier	259A1452P1	01
181	GCT Support	245A8425P1	01
186	Coil Stab Asm LV	194A6912G1	01
194	Ground Stud NP	194A6999P2	01
211	HV Grommet	577A180P3	02
209	CPT Fuse Supt Asm	194B6370G2	01
213	CPT Cable Clamp	104B9335P5	04
218	Handle Asm	116C9928G1	01
250	Bus Insul. (Back Cover)	149B1741P1	01
268	Hor & Ver Bus Asm	116C9952G2	01
269	Vert Bus Barrier	205A4508P1	01
272	Motor Stab Insul	259A3226P1	01
273	Insul Supt	259A5042P1	01
274	Insul Supt	259A5041P1	01
274	AC Bus Splice	193A7666P	03
275	Motor Term Asm Upr	157C8151G1	01
275	Motor Term Asm Low	149B1779G2	01
276	Compartment Barrier	68J120134FP0000AAB	01
280	Inc Power Bus Term	193A7124P1	01
281	Inc Power Bus Term	193A7124P2	01
289	Ground Bus	148B45352P4	01
293	Ground Bus	148B5352P4	01
295AA	Ground Bus Splice To 1-Hi	193A7351P1	01
295AC	Ground Bus Splice To 1-Hi	193A7351P1	01
295AD	Ground Bus Splice To 1-Hi	193A7351P3	01
295AE	Ground Bus Splice To 1-Hi	193A7351P3	01
297	Ground Bus	148B5352P4	01
299	Ground Bus	148B5352P4	01
299	Wire Harness	711BR29	01
300	Spacer	194A7014P2	02
309	Motor Stab Asm	116C9929G2	01
310	Track & Barrier Asm	116C9939AAG2	01
311	Track Supt Block	194A7014P1	02
313	Track Supt Block	194A7014P3	02
315	Defeater - Latch Asm NP	194A6916G1	01
315	Defeater - Latch Asm Lo	194A6916G4	01
508	Term Bd Supt	194A7176P1	02

Mtl List Part No.	Part Name Description	Typical Catalog Number (Variable)	Qty.
509	13 Pt Term Bd	CR151B213B	02
510	13 Pt TB Mark Strip	125A5978P3	02
553	LV Base	68J120125GL0000AAB	01
632	LV Door Latch Asm	117B5064G3	01
635	HV Door Latch Asm	104B9336G2	02
645	HV Door Upper	68J210551CMXXXXXB	01
645	HV Door Lower	68J210551CLXXXXXB	01
646	HV Door Vent Barrier	205A4475P2	01
653	LV Door Var. No.	68J2 B	01
660	Hdl Instr. NP	272A565ESP1	01
667	Door Hinges	174A4728G1	04
668	Hinge Pins	1459941P1	04
700	L Ver Bar Up Mot Cab	68J220134FS0000AAB	01
702	Inc Line Barr Upr	68J220134FK0000AAB	01
704	Inc Line Barr Lwr	68J120134FM0000AAB	01
705	LV Bases Barrier	68J120125FR0000AAB	01
707	RH Rear Barr Upr	68J210553BAXXXXXXB	01
708	RH Rear Barr Ctr	68J120125FD0000AAB	01
709	RH Rear Barr Lwr	68J120553BXXXXXB	01
711	Bottom Ver Bus Barr	194A6968P2	01
715	RH Mot Barr Upr	68J220134FY0000AAB	01
716	RH Mot Barr Ctr	68J220134FE0000AAB	01
717	RH Mot Barr Lwr	68J120134FT0000AAB	01
718	RH Mot Barr Front	68J120134FW0000AAB	01
728	Cont. Latch Asm	194A6949G1	01
742	Shutter Asm	116C9931G1	01
809	Panel Data NP	259A8798P1	01
812	Comp NP	NP161868	01
859	Bus Cover Plate	68J120125BM0000AAB	02
862	Plug Bottom LV Side	N529P5886	02

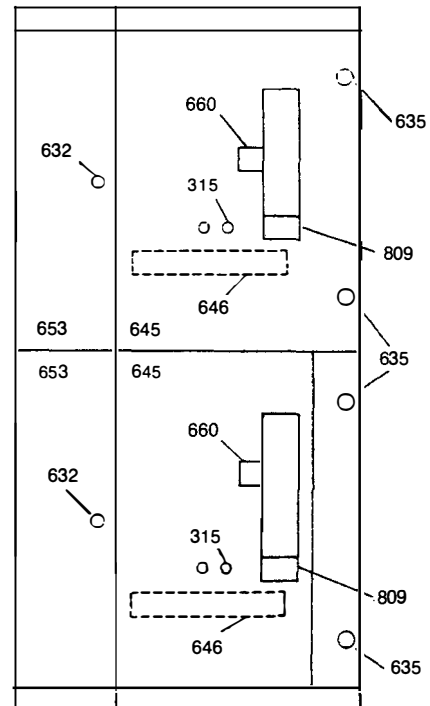

Doors and related parts only

① Catalog numbers in list are for only (1) combination. See req'n Material List for actual list.

② See page 11.

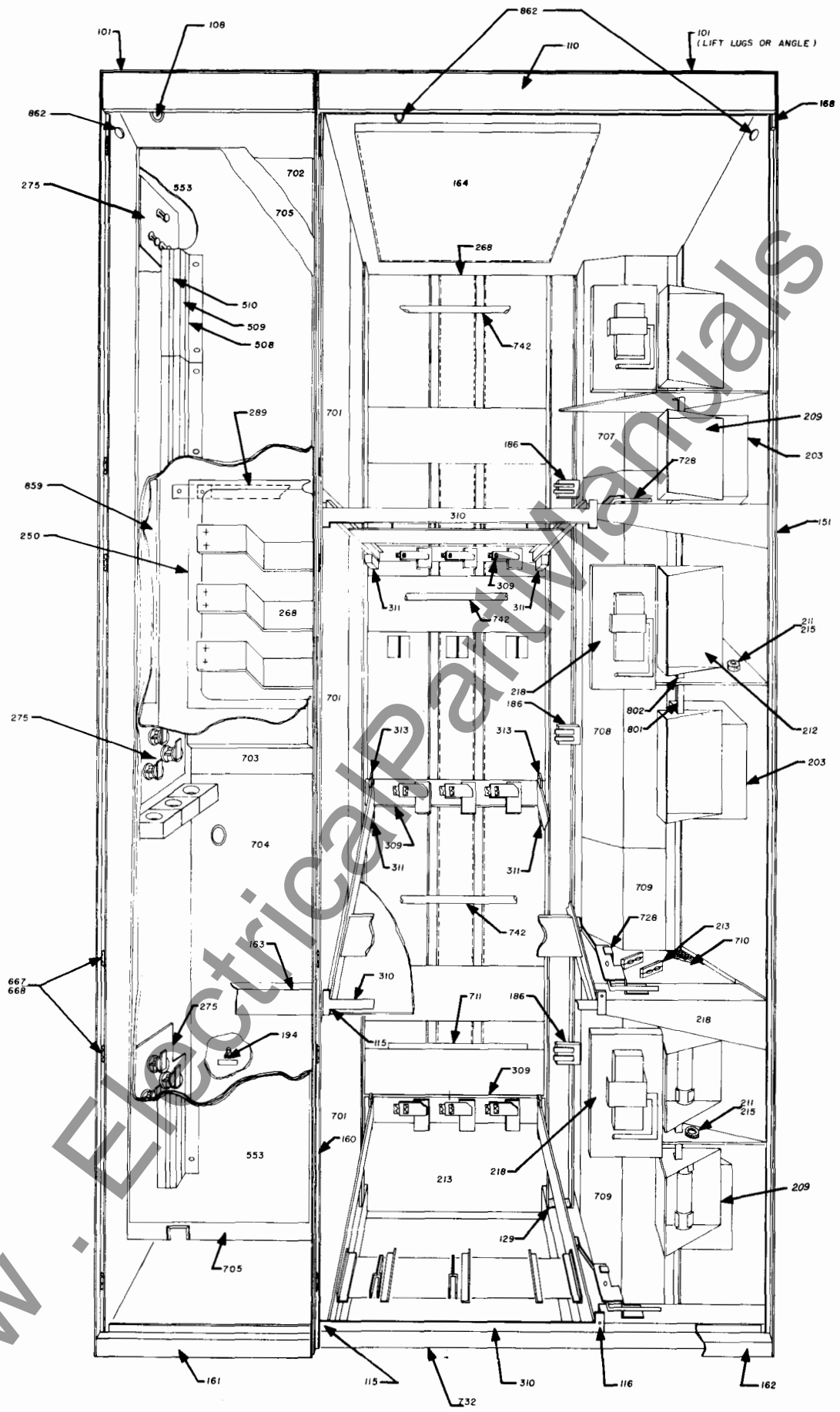

Three-high Construction

Three-high Parts List①

Mtl List Part No.	Part Name Description	Typical Catalog Number (Variable)	Qty.
101	Lifting Lug	288A593P1	01
108	Plug Button	N529P6386	01
111	Publicity NP	194B6315P1	01
115	Left Track Sup	139B8564G3	01
116	Right Track Sup	139B8564G4	01
129	Washer Plate	194A7383P1	06
151	Shell Asm	68J210550BA449030B	01
160	Vertical Lintel	68J210552BAXXXXXXB	01
161	Bot LV Lintel	149B3258P1	01
162	Bot HV Lintel	68J120125ET0000AAB	01
163	LV Mullion	174A8913G1	02
164	Dust Shield	68J120125EU0000AAB	01
168	Gasket NEMA 1	117B4557G1	01
168	Gasket NEMA 1A, 3, 12	118B7100G2	01
180	Sems Unit	577A179P1	28
186	Coil Stab Asm LV	194A6912G1	01
194	Ground Stud NP	194A6999P2	01
211	HV Bush Male	161A8674P3	01
209	CPT Fuse Supt	149B1782G1	01
213	CPT Cable Clamp	104B9335P5	02
215	HV Bush Female	167A8405P3	01
218	Handle Asm	116C9928G1	01
250	Bus Insul. (Back Cover)	149B1741P1	01
268	Hor & Vert Bus Asm	116C9952②	01
275	Motor Term Asm Upr	149B1779G1	01
275	Motor Term Asm Low	149B1779G2	01
289	Ground Bus	148B5352P4	01
299	Wire Harness	7118R29	01
309	Motor Stab Asm	116C9929G2	01
310	Track & Barrier Asm	116C9939AAG3	01
310	Track & Barrier Asm	116C9939AAG2	01
311	Track Supt Block	194A7014P1	02
313	Track Supt Block	194A7014P3	02
315	Defeater - Latch Asm	194A6916G1	91
508	Term Bd Supt	194A7176P1	02
509	13 Pt Term Bd	CR151B213B	02
510	13 Pt TB Mark Strip	125A5978P3	02
553	LV Base	68J120132GE0000AAB	01
632	LV Door Latch Asm	117B5064G3	01
635	HV Door Latch Asm	104B9336G2	02
645	HV Door	68J210551CAXXXXXXB	01
646	HV Door Vent Barrier	205A4475P1	01
653	LV Door Mod-Var No.	68J2 B	01
660	Hdl Instr NP	272A5651ESP1	01
667	Door Hinges	147A4728G1	04
668	Hinge Pins	1459941P1	04
701	L Ver Barr Up Mot Cab	68J210553BDXXXXXB	01
702	Inc Line Barr Upr	68J210553CXXXXXB	01
703	Inc Line Barr Ctr	194A6922G1	01
704	Inc Line Barr Lwr	68J120125FM0000AAB	01
705	LV Bases Barrier	68J120125FR0000AAB	01
707	RH Rear Barr Upr	68J210553BAXXXXXXB	01
708	RH Rear Barr Ctr	68J120125FD0000AAB	01
709	RH Rear Barr Lwr	68J210553BBXXXXXB	01
710	CPT Fu Hor Barrier Perf	68J120125FF0000AAB	01
711	Bottom Ver Bus Barr	194A6968P2	01
728	Cont. Latch Asm	194A6949G1	01
732	HVC Bolt Label	218A4255P1	01

Mtl List Part No.	Part Name Description	Typical Catalog Number (Variable)	Qty.
742	Shutter Asm	116C9931G1	01
801	Fuse Supt	194A7152G2	01
802	Fuse Supt	194A7152G3	01
809	Panel Data NP	259A8798P1	01
812	Compt. NP	NP161868	01
859	Bus Cover Plate	68J120125BM0000AAB	02
862	Plug Bottom LV Side	272A5651GDP5	02

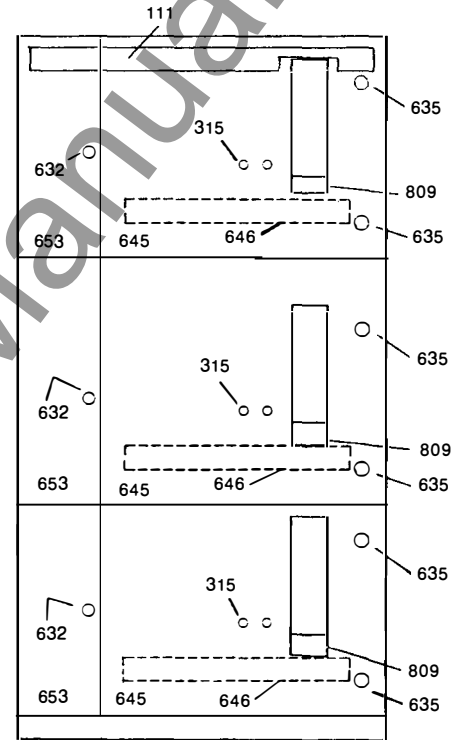

Doors and related parts only

① Catalog numbers in list are for only (1) combination. See req'n Material List for actual list.
 ② See page 11.

Handle Assembly

The non-loadbreak isolating mechanism (handle assembly) is a complex assembly requiring a special bench fixture for assembly and special gauges for adjustment of the mechanical interlocking mechanisms. We recommend, therefore, that if the handle mechanism becomes extensively damaged the entire assembly be replaced.

Entire assemblies are ordered by catalog number 116C9928G* (see table below). The group number (G*) is found on an adhesive backed label stuck on the underside of the handle housing (see below). Entire assemblies can be ordered as follows:

Type of Starter Unit	Catalog Number
Full-voltage non-reversing	116C9928G1
Reduced-voltage Non-reversing	116C9928G5
Full-voltage reversing-standard	116C9928G2
Full-voltage reversing-mine hoist	116C9928G1
Reduced-voltage reversing	116C9928G2
Wye-delta	116C9928G1
Part winding-contactors in series	116C9928G1
Part winding-contactors in parallel	116C9928G5
Two-speed, one-winding	116C9928G2
Two-speed, two-winding	116C9928G2

Some parts of the handle assembly are replaceable and can be identified by part number as shown below:

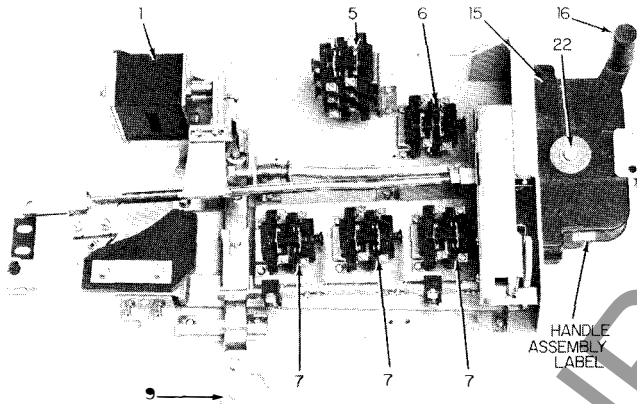

Part Number	Description	Catalog Number
1	Brain box	979B444G*
5	Test power interlocks	205A5718G5
6	Control power interlocks	723B245G274
7	Contact auxiliary interlock	723B245G273
9	Sensor bar hook	194A7033P4
9	Weld nut assembly for hook	194A7033G1
15	Handle housing-standard	149B1759G1
15	Handle housing-if key interlocked	149B1759AAP1
16	Handle-standard	149B1746G1
16	Handle-if key interlocked	194A7179P1
22	Handle retainer clip	N910P62C6

* Group numbers for the 979B444 brain box are per starter type as follows:

Full-voltage non-reversing	G12
Reduced-voltage non-reversing	G14
Full-voltage reversing	G13
Reduced-voltage reversing	G13
Wye-delta 1M contactor	G12
Wye-delta 2M contactor	G13
Part-winding contactors in series	G12
Part-winding contactors in parallel	G14
Two-speed, one-winding	G13
Two-speed, two-winding	G13

One-high Vertical Bus Assembly 194A4480G*

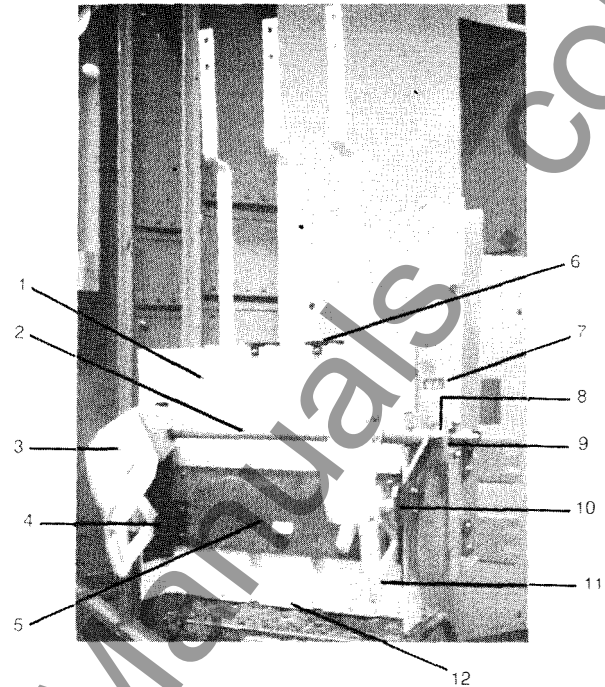

* Complete assembly numbers can be found on page 11. The identification sticker (Part No. 7) identifies the 194A4480 group number of the complete assembly as shown. If part number 7 is not found, you must furnish the section catalog number and unit diagram number (see page 3).

Part No.	Qty.	Description	Catalog Number
1	1	Front Vertical Bus Cover	116C9921P5
2	1	Shutter Operator Pipe	139B8559G1
3		Contact Operator ①	
	1	Right Hand	169C6351ATG1
	1	Left Hand	169C6351ATG2
4	2	Shutter Bracket	194A6908P1
5	1	Shutter	149B1748P2
4, 5	1	Shutter Assembly	149B1752G1
6	2	Holding Clamp	194A4466P1
7		Identification Sticker
8	2	Pipe Collar	181A4108P2
9	2	Bearing Plate	188A5537G1
10	2	Shutter Operator Bearing Support	139B8561G1
11		Shutter Operator	
	1	Right Hand	149B1768G1
	1	Left Hand	149B1768G2
12	1	Bottom Vertical Bus Barrier	194A6968P2

① Previous part numbers 149B1749G1, G2. New parts must be ordered in pairs when replacing old parts.

See page 12 for bare bus bar assemblies and information. Bare bus assemblies will only be furnished in one-high construction.

Two-High Vertical Bus Assembly 116C9952G*

Three-High Vertical Bus Assembly 116C9930G*

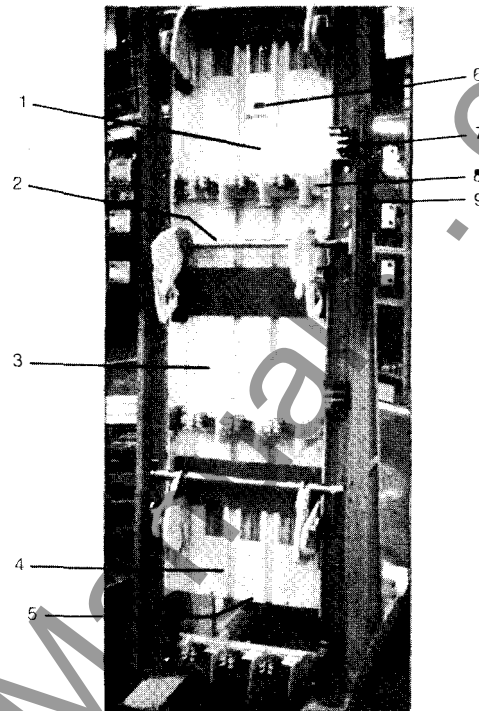
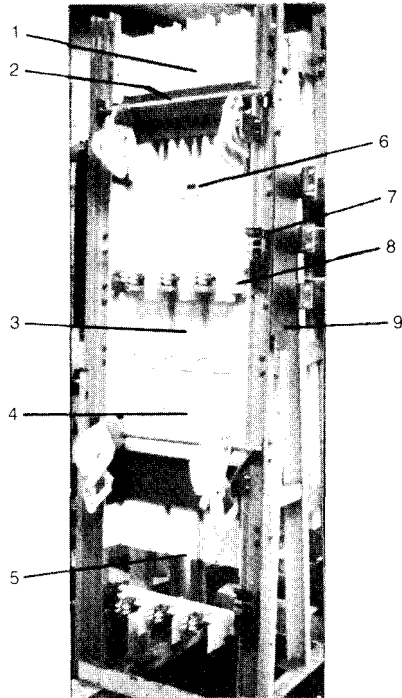

* The identification sticker (Part No. 6) identifies the 116C9952 Group Number of the complete assembly as shown. If part number 6 is not found, you must furnish the section catalog number and unit diagram number (see page 3).

* The identification sticker (Part No. 6) identifies the 116C9930 Group Number of the complete assembly as shown. If part number 6 is not found, you must furnish the section catalog number and unit diagram number (see page 3).

Part No.	Qty.	Description	Catalog Number
1	1	Top Vertical Bus Cover	116C9921P7
2	1①	Shutter Operator Pipe	139B8559G2
3	1	Middle Vertical Bus Cover	194B6318P1
4	1	Bottom Vertical Bus Cover	116C9921P4
5	1	Bottom Vertical Bus Barrier	194A6968P2
6	—	Group Identification Sticker
7	1①	Coil Finger Assembly	194A6912G1
8	1①	Motor Stab Assembly	116C9929G2
9	2	Bus Insulator Barrier	233A2445P1

① These parts are variable from 1 to 2, depending on the number of equipped spaces.

These represent the only parts recommended for replacement by user.

Part No.	Qty.	Description	Catalog Number
1	1	Top Vertical Bus Cover Blank Top Cover	116C9921P2 116C9921P1
2	1①	Shutter Operator Pipe	139B8559G2
3	1	Middle Vertical Bus Cover Blank Middle Cover	116C9921P3 116C9921P6
4	1	Bottom Vertical Bus Cover	116C9921P4
5	1	Bottom Vertical Bus Barrier	194A6968P2
6	—	Group Identification Sticker
7	1①	Coil Finger Assembly	194A6912G1
8	1①	Motor Stab Assembly	116C9929G2
9	2	Bus Insulator Barrier	233A2445P1

① These parts are variable from 1 to 2, depending on the number of equipped spaces.

These represent the only parts recommended for replacement by user.

www.ElectricalPart.com

One-high Vertical Bus Assemblies

A one-high vertical bus assembly consists primarily of the bus bars, shutter, and operator assembly all assembled as one item. The complete assembly is the easiest to replace, however, if the user has the expertise the bare bus bar assembly can be installed in the field.

The following table is a cross reference from the complete assembly group number (194A4480G*, see page 10) to the bare bus bar assembly (116C992_G_) shown in the following table.

If the sticker cannot be located (item 7, page 10), the section catalog number and diagram number must be referenced for the factory to determine the correct group number.

Complete Assembly	Bare Bus Assembly	Complete Assembly	Bare Bus Assembly
194A4480G1	116C9925G1	194A4480G25 ^③	116C9925G16
194A4480G2	116C9925G2	194A4480G26	116C9925G17
194A4480G3	116C9926G1	194A4480G27	116C9925G18
194A4480G4	116C9925G1	194A4480G28	116C9925G19
194A4480G5	116C9925G2	194A4480G29	116C9925G20
194A4480G6	116C9926G1	194A4480G30	116C9925G21
194A4480G7	116C9925G3	194A4480G31	116C9925G22
194A4480G8	116C9925G4	194A4480G32	116C9925G23
194A4480G9 ^①	116C9925G25	194A4480G33	116C9925G24
194A4480G10 ^①	116C9925G6	194A4480G34 ^②	116C9925G25
194A4480G11 ^①	116C9926G2	194A4480G35 ^②	116C9925G19
194A4480G12	116C9925G8	194A4480G36 ^②	116C9925G20
194A4480G13	116C9925G9	194A4480G37	116C9925G13
194A4480G14	116C9925G7	194A4480G38	116C9925G14
194A4480G15	188A4200UEG1	194A4480G39	116C9925G23
194A4480G16 ^②	116C9925G10	194A4480G40	116C9925G24
194A4480G17	187B9490G1	194A4480G41 ^②	116C9926G7
194A4480G18	116C9926G4	194A4480G42	116C9925G26
194A4480G19 ^②	116C9926G5	194A4480G43	116C9925G27
194A4480G20	116C9925G12	194A4480G44	116C9925G30
194A4480G21	116C9925G13	194A4480G45	116C9925G31
194A4480G22	116C9925G14	194A4480G46	116C9926G8
194A4480G23	116C9926G6	194A4480G47	116C9926G9
194A4480G24 ^③	116C9925G15		

Note: Bare bus bar assemblies are not available in two-high or three-high construction. Order complete vertical bus assemblies as shown on pages 10 and 11.

- ① Group 9 has been replaced by Group 24.
Group 10 has been replaced by Group 25
Group 11 has been replaced by Group 26
- ② For use with 700-ampere contactor
- ③ 1983 to current date—standard for 400-ampere contactor

Stab Assemblies

There are two types of stab assemblies in Limitamp Control; motor stabs and intermediate stabs (for either control power transformers in most cases, or for the reversing contactor in a full-voltage reversing starter function). Assemblies can be identified from the spare parts bill-of-material furnished with the equipment, or if bill-of-material is lost or misplaced, they may be identified by the description below.

The motor stab assembly for one-high construction can be found as part number 309 on page 5. The motor stab assembly for two-high and three-high construction is also part number 309 which can be found on pages 7 and 9, however, the catalog number is different for two- and three-high versus one-high construction.

The intermediate stabs for one-high construction are found as part number 212 on page 5 and differ extremely from the intermediate stab assemblies, part number 310, found on pages 7 and 9. Care should be exercised when ordering stab parts. Intermediate stab assemblies are also listed below for one-high construction. For two- and three-high construction, see pages 7 and 9 for intermediate stab assembly Catalog Numbers.

The one-high construction assembly numbers are listed for both 400 and 700 ampere contactors while for two- and three-high construction only the 400 ampere contactor is available.

Description	Assembly Numbers		
	400 Amperes One-high	700 Amperes One-high	Two-high & Three-high
Motor Stab	149B1743G4	149B1743G8	116C9929G2
Intermediate Stab, 2-pole	149B1743G6	149B1743G6
Intermediate Stab, 3-pole Non-reversing Starter	149B1743G5	149B1743G5	(See Page 14)
Intermediate Stab, 3-pole Reversing Starter	149B1743G5	149B1743G10

It is possible to furnish some individual parts or smaller assemblies than those listed above. See the following pages for these parts or assemblies.

One-high Stab Assembly, Motor And Intermediate 149B1743G*

* Group numbers listed in schedule below.

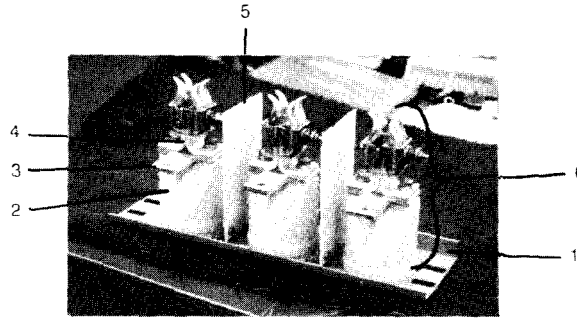

For stab fingers only, see page 14

Part No.	Description	Catalog Number (149B1743G*)									
		Qty.	Group 4	Qty.	Group 5	Qty.	Group 6	Qty.	Group 8	Qty.	Group 10
1	Stab Base	1	149B3225P1	1	68J120125CA-0000AAB	1	68J120G25CA-0000AAB	1	149B3225P1	1	68J120125CA-0000AAB
2	Insulator	3	218A683P1	3	218A6831P1	2	218A6831P1	3	218A6831P1	3	218A6831P1
3	Terminal	3	194A7007P3	3	194A7007P3	2	194A7007P3	3	194A7007P2	3	194A7007P2
4	Stab Support Bracket	6	979B468P6	6	979B468P6	4	979B468P6	6	193A7754G1	6	193A7754G1
5	Phase Barrier	2	272A5651FJP1	2	272A5651FJP	1	272A5651FJP1	2	272A5651FJP1	2	272A5651FJP1
6	Individual Stab Asm (Complete)	3	149B1744G7	3	149B1744G7	2	149B1744G7	3	149B1744G2	3	149B1744G2

Note: 149B1743G8 and G10 are for use with the 700-ampere contactor

Two- And Three-high Motor Stab Assembly 116C9929G2

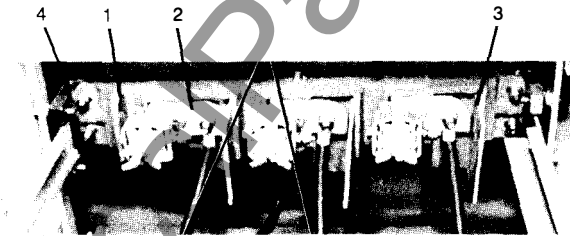

For stab fingers only, see page 14.

Part No.	Description	Qty.	Catalog Number
1	Stab Base	1	116C9911P1
2	Stab Support & Terminal	3	194A690G3
3	Phase Barrier	3	259A8764P1
4	Base Support		
	Left Side	1	194A7015G1
	Right Side	1	194A7015G2

Intermediate Stab And Track Assembly 116C9939AAG2 And G3

Track Assemblies are used in two- and three-high enclosures to support the contactor. This assembly includes the intermediate stabs.

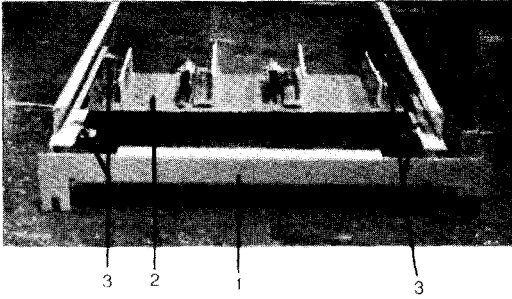

Note:

Group 2 assemblies are used in both two-high positions and in the bottom of three-high position.

Group 3 assemblies are used in the top and middle three-high positions only.

Ground Finger assemblies for Group 3 tracks in older starters can be added to the new Group 3 tracks to make a complete replacement assembly. Ground finger assembly catalog number: 149B1781G2.

Part No.	Description G2 & G3	Qty.	Catalog Number
1	Track Frame	1	171B6050G1
2	Intermediate Stab	1	169C6351ASG1
3	Roller	4	245A7436P1
4	Barrier (not shown). Mounts on Underside of G3 Assembly Only	1	194A6946P1

Intermediate Stab Assembly 169C6351ASG1①

① If there are no stab fingers (two-speed, one-winding unit only), order part number 137D7076AAP2.

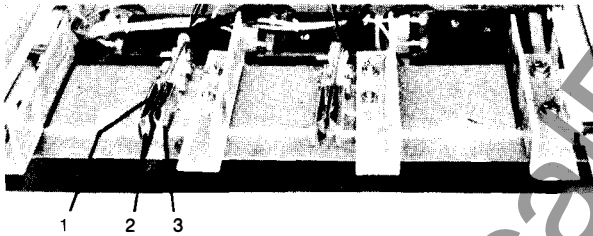

Part No.	Description	Qty.	Catalog Number
1	Short Finger Support	1	194A7046P2
2	Stab Fingers	2	194A7047P1
3	Long Finger Support	1	45A7536P1

Note: If any fiberglass parts are damaged, a complete assembly must be ordered.

Stab Finger Parts

(Common To All Stab Assemblies, See Page 13)

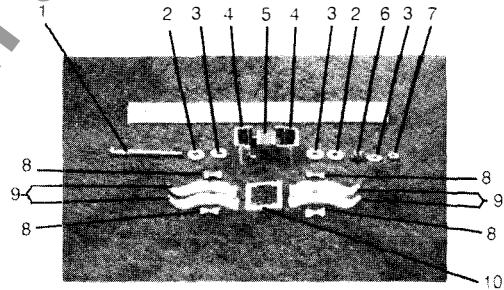

Part No.	Description	Qty.	Catalog Number
1	Bolt	1	N22P21044B6
2	Steel Washer	2	N402P41B6
3	Insulated Washer	2	302A3449AMP1
4	Retainer	2	125A4282P1
5	Retainer	1	125A4281P1
6	Spring	1	174A4422P1
7	Locking Nut	1	577A251P2
8	Spacer	4	125A4279P1
9	Stab Finger	4	125A4278P1
10	Retainer	1	125A4280P1

CPT Fuse Support Assemblies

CPT primary fuse support assemblies are most easily identified by using the fuse catalog number, type of enclosure (one-high, two-high, three-high) and the matrix below. This will provide the complete fuse support assembly catalog number. *Note: Fuse catalog numbers are stamped on one end of the fuse ferrule.*

Fuse Catalog Number	Enclosure Type					
	Qty.	One-high Catalog Number	Qty.	Two-high Catalog Number	Qty.	Three-high Catalog Number
9F60AAB002	1	117B5338G1	1	194B6370G2	2	149B1782G2
9F60BBD003	1	104B9352G1	1	194B6370G1	2	149B1782G1
9F60CCB007	1	104B9352G2	---	-----	---	-----
9560CED005	1	104B9352G3	---	-----	---	-----

Fuse support assembly catalog numbers are also found in the bill of material provided with the spare parts list under item 209 (see pages 5, 7, and 9). If individual parts or pieces are required, use the following tables.

104B9352G1, G2, G3			117B5338G1		
Part Number	Qty.	Catalog Number	Part Number	Qty.	Catalog Number
Insulator	2	218A6831P1	Insulator & Clip Support	4	181A1738P1
Clip Support Barrier	2	981B113P5	Terminal	4	151A6185P1
Terminal	4	104B9353P4	Clip	4	75A105271P101
G1 Clip	4	104B9353P3			
G2 & G3 Clip	8	104B9353P1			
G2 & G3 Steel Spring Clip	4	104B9353P2			

194B6370G1, G2			149B1782G1, G2		
Part Number	Qty.	Catalog Number	Part Number	Qty.	Catalog Number
Insulator & Clip Support	1	116C9933P1	Insulator & Clip Support	2	116C9933P1
G1 Terminal	2	194A7150P1	G1 Terminal	4	194A7150P1
G2 Terminal	2	194A7150P2	G2 Terminal	4	194A7150P2
G1 Clip	2	104B9353P3	G1 Clip	4	104B9353P3
G2 Clip	2	75A105271P101	G2 Clip	4	75A105271P101
			Phase Barrier	1	259A3213P1

Examples of fuse support assemblies can be found in GEH-3091C:

One-high; Figure 55

Two-high; Figure 42

Three-high; Figures 43 and 45

www.ElectricalPartManuals.com

Outside the U.S. and Canada, write Export Sales and Trading,
570 Lexington Avenue, New York, NY 10022

For further information call or write your local General Electric distributor or sales office. Or write . . .	General Electric Company General Purpose Control Department P. O. Box 489 Mebane, NC 27302
---	--

