



INSTALLATION • OPERATION • MAINTENANCE INSTRUCTIONS

TYPE KX COMPENSATOR

APPLICATION

The Type KX Compensator provides a secondary voltage which is proportional in phase and magnitude to the voltage drop thru a power transformer bank. Thus, the compensator with its associated current and potential transformers make possible the reliable measurement of transmission line relay potential from bus potential transformers. This is often economically advantageous in the application of impedance or distance type relays where the impedance of the power transformer bank is not included as a part of the transmission line and where potential transformers are not available on the transmission lines. In the usual case distance type relays are desired to protect a high-voltage transmission line where only low voltage potential transformers are available.

Distance type relays such as the types HZ, HCZ, CZ and HY relays view electrical distance (impedance and reactance) from the point on the system where the relay potential is measured. If this potential is taken from the low voltage bus and if fault power flows thru the transformer bank for high voltage line faults, then the voltage of the low voltage potential transformers for these faults will be relatively higher than the respective voltage on the high voltage potential transformer by the impedance drop thru the transformer bank. To the distance relay set only on the basis of the transmission line impedance and using low voltage potential, the line fault would appear to be further away from the high voltage side of the bank than it actually is. However, if there is no power source connected to the low voltage bus, then there is no fault power fed thru the bank, and the low and high voltage potential are essentially equivalent. In this last case the

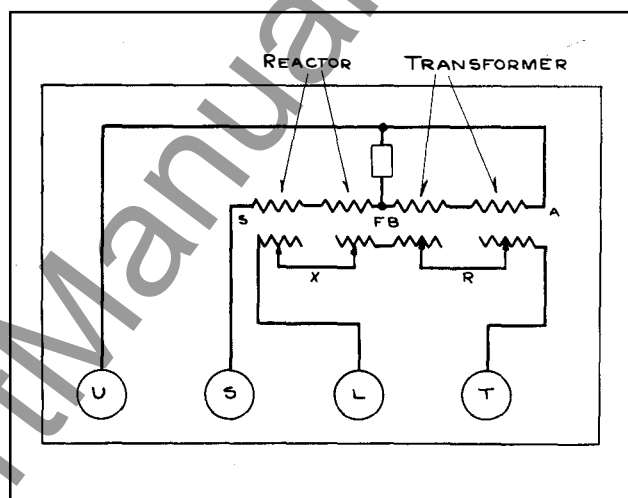

Fig. 1—Schematic Connection of the Type KX Compensator.

low voltage potential transformers may be used for distance relays without Type KX Compensators.

CONSTRUCTION AND OPERATION

The Type KX Compensator consists of a reactance transformer and transformer connected with both their primary and secondary windings in series as shown in Fig. 1. The reactance transformer contains air gaps in its magnetic circuit so that the magnetizing current is large and consequently the voltage induced in its secondary winding is approximately 90° out of phase with the primary current. This element provides reactive compensation.

The transformer which supplies the resistive compensation has its magnetic circuit designed to give a low magnetizing current. A resistor is connected across the primary windings causing the transformer primary current to lag the total input current. This combination shifts the secondary induced voltage until it is

TYPE KX COMPENSATOR

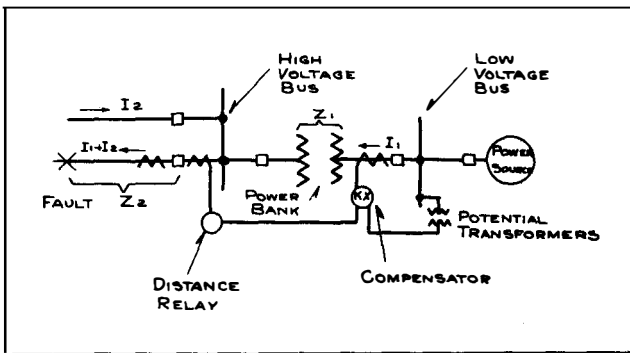

Fig. 2—General Case For The Application of The Type KX Compensator Thru One Power Transformer Bank.

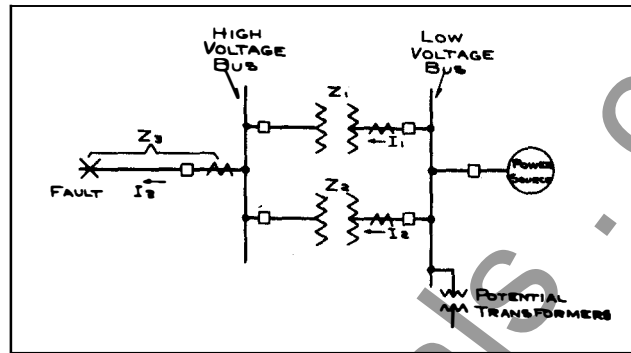

Fig. 3—General Case For The Application of The Type KX Compensator Thru Two or More Power Transformer Banks.

approximately in phase with the total input current.

The Type KX Compensator is energized from current transformers giving a current proportional to the current thru the power transformer. It is adjustable so that a voltage may be produced by the current proportional to and in phase with the voltage drop thru the power transformer. By properly combining this voltage drop with the low tension voltage, a voltage exactly proportional to and in phase with the desired high tension voltage is obtained. This latter voltage is applied to the distance relay potential coils.

The terminals U and S of the schematic wiring Fig. 1 are the current terminals and the terminals L and T are the voltage terminals. By properly adjusting the R and X values the voltage produced across terminals L and T by the current flowing between U and S will be proportional to and in phase with the drop in the transformer. Under these conditions the ratio between R and X in the compensator will be the same as the ratio between R and X in the power transformer.

CHARACTERISTICS

Two ranges of the Type KX Compensator are available, and are:

Style #	Compensation Range (Volt at 5 amps.)		Max. Secondary Impedance (Ohms)
	Resistive	Inductive	
458551	0-4	3.4-9	5
458552	0-4	6-16	9

The resistance and reactance drop produced in the compensator for each setting is marked on the compensator as shown in Figs. 9 and 10.

These values are based on the assumption that 5 amperes are flowing thru the primary of the compensator. Thus if the resistance and reactance drops in the power transformer are known, the current thru the compensator under full load conditions may be calculated and from this the proper setting computed. This is covered under Settings.

The polarity of the Type KX Compensator is such that at the instant current is flowing in at terminal S and out at U, the terminal L is positive with respect to terminal T.

The secondary windings of the compensator are connected in series with the low voltage potential transformer secondary winding and the relays. Since the compensator secondary windings necessarily have some impedance, the voltage across the relay coils will be slightly less than the potential transformer secondary voltage at zero compensation. With a fixed relay burden this compensator impedance voltage drop is always a constant percentage of the total voltage. This percentage for one set of either the type HZ, CZ, or HCZ relays is less than 2.5% with the maximum compensator setting of 9 ohms and the minimum relay burden. If the potential burden imposed on the potential transformers and compensators is increased giving an appreciable drop across the compensator, the distance relay can still be set accurately by taking

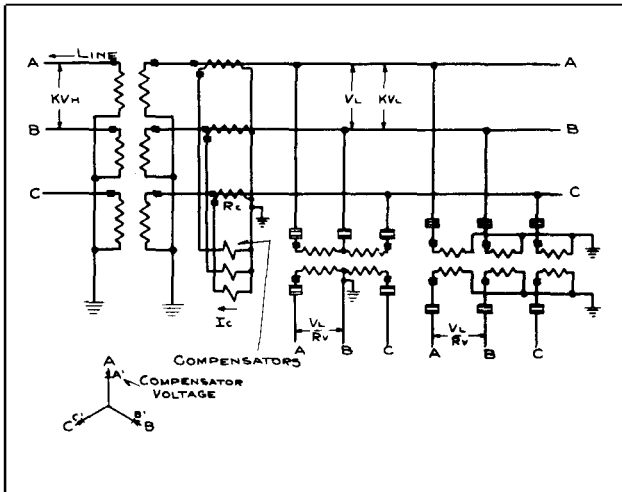

Fig. 4—Schematic Compensation Diagram for Star-Star (Or Delta-Delta) Connected Power Transformer Banks.

into account the reduced relay voltage in the relay tap formula. For example in setting the type HZ impedance relay the formula is:

$$TS = \frac{10 Z R_C}{R_V}$$

Now if the compensator voltage drop is 10% of the total drop so that the relay only receives 90% voltage, then the formula can be modified by increasing the potential transformer ratio thus,

$$TS = \frac{10 Z R_C}{1.1 R_V}$$

CONNECTIONS AND SETTINGS

The general installation requiring the Type KX Compensators is shown schematically in Fig. 2. The distance relay protecting the high voltage line should respond only to the impedance Z_2 which would be the case if the current for the relay is taken from current transformers in the location shown and if the potential transformers measured the high voltage bus potential. But with low voltage potential transformers the relay voltage is increased by the drop $I_1 Z_1$ thru the power transformer bank. Therefore, the Type KX Compensators are required and should be connected to receive I_1 and set to produce a secondary voltage drop equal to $I_1 Z_1$.

Quite often there are two or more power

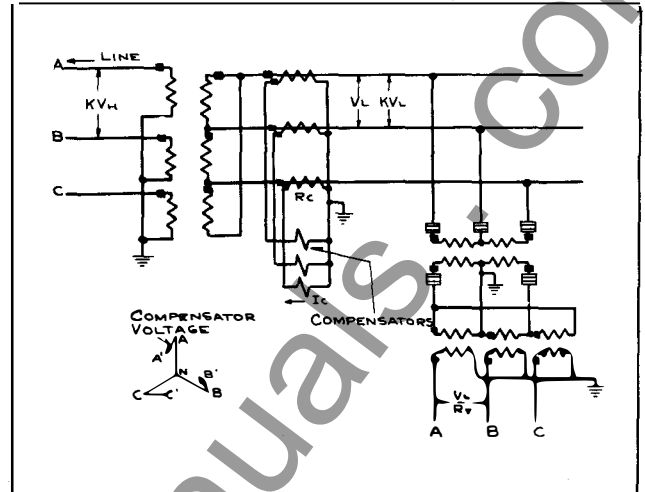

Fig. 5—Schematic Compensation Diagram For Star-Delta Connected Power Transformer Banks With Current Transformers Outside Delta.

banks connecting the high and low voltage busses together. The general case with two banks is shown in Fig. 3. The voltage drop between busses in this case is $I_1 Z_1 = I_2 Z_2$ so that only one set of compensators is necessary receiving either I_1 or I_2 current and set for the corresponding impedance Z_1 or Z_2 respectively. If the bank on which compensators are connected is removed from service, than an additional set of compensators or some switching arrangement if the bank impedances are equal must be used to provide proper relay potential.

There are a variety of connections and respective settings which can be made depending on the current transformer locations and the power bank connections. The most common of these for both two and three winding transformer banks will be considered. The three winding bank cases are the same as the two winding banks where fault power is not fed from one of the windings such as the tertiary winding. The following nomenclature will be used.

$\%R, \%X, \%Z^*$ Resistance, reactance, and impedance respectively, of the power transformer bank in percent.

R, X, Z^* Resistance, reactance, and impedance

* Subscripts H, L and T represent equivalent star values of three winding transformers defined in equations 16, 17 and 18.

TYPE KX COMPENSATOR

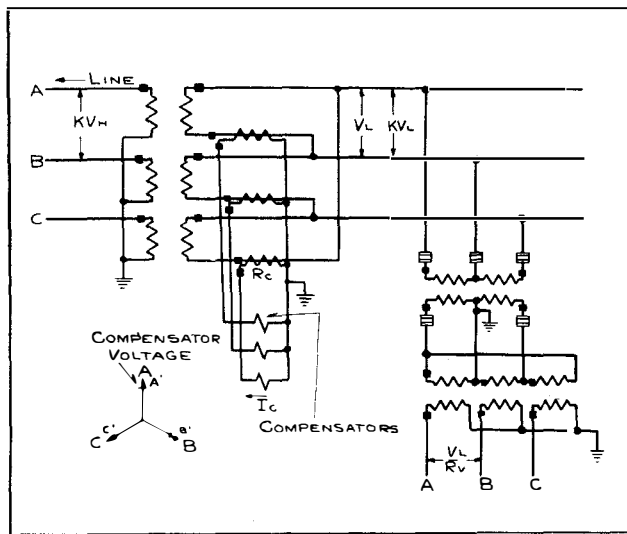

Fig. 6—Schematic Compensation Diagram For Star-Delta Connected Power Transformer Banks With Current Transformers Inside Delta.

CASE I Star-Star or Delta-Delta Connected Power Transformer.

In this case the compensators are connected in star to star-connected low voltage current transformers as shown in Fig. 4. Then the compensator current is,

$$I_C = \frac{(KVA)}{\sqrt{3} (KV_L) (R_C)} \text{ amperes} \quad (1)$$

By definition the percent impedance of the power transformer is the percent voltage drop across the bank at unit current. As shown in the vector diagram of Fig. 4 the compensating voltage is in phase with a star current. Therefore, the voltage drop across the bank at unit current (in this case I_C) in terms of the star relay voltage is,

$$\frac{V_L}{\sqrt{3} (R_V)} \times \frac{(\%Z)}{100} \text{ volts} \quad (2)$$

The compensators are calibrated in volts when rated 5 amperes is flowing thru the primary. Then the compensator setting to give a voltage drop equivalent to the drop across the transformer bank is,

$$\begin{aligned} \frac{5}{I_C} \times \frac{V_L (\%Z)}{\sqrt{3} (R_V) (100)} \\ = \frac{5 (V_L) (KV_L) (R_C) (\%Z)}{(KVA) (R_V) (100)} \end{aligned} \quad (3)$$

The same formula also may be easily derived from the ohm values of R, X and Z instead of the more common percent values. The secondary voltage drop across the transformer bank is $\frac{IZ}{R_V}$ and the compensation primary current is $\frac{I}{R_C}$. Since the compensator is calibrated for 5 amperes in its primary, the compensator setting is,

$$\frac{5R_C}{I} \times \frac{IZ}{R_V} = \frac{5ZR_C}{R_V} \text{ volts} \quad (4)$$

This is equal to the formula above since

$$Z \text{ Ohms} = \frac{10 (KV_L)^2 \times \%Z}{KVA} \quad (5)$$

Therefore, for Star-Star or Delta-Delta connected power transformers with star connected compensators on the low voltage side,

respectively, of the power transformer banks in ohms at the low voltage base V_L .

KVA KVA base of the values of $\%R$, $\%X$ and $\%Z$ above.

V_L Line to line voltage of the low voltage side of the bank where the relay potential transformers are available.

KV_L Line to line kilovolts of the low voltage side of the transformer bank.

KV_H Line to line kilovolts of the high voltage side of the transformer bank.

KV_T Line to line kilovolts of the tertiary winding of a three winding transformer bank.

R_V Potential transformer ratio.

R_C Compensator current transformer ratio.

I_C Current thru compensator primary windings in amperes.

the following formula applies:

$$\text{Comp. Setting} = \frac{50 (KV_L)^2 R_C (\%Z)}{(KVA) R_V} = \frac{5ZR_C}{R_V} \text{ volts (6)}$$

This formula will give the resistive and reactive compensator settings by substituting either $\%R$ or R and $\%X$ or X in place of $\%Z$ or Z . If the calculated tap setting does not agree with any combination of values on the compensator, the next lower tap should be used to avoid over compensation.

CASE II Star-Star or Delta-Delta or Star-Delta Connected Power Transformer.

(Similar to Fig. 4 except compensation current transformers on high voltage side of bank). This is the same as the case above except equation (1) is in terms of KV_H instead of KV_L . Therefore, for star-star connected power transformers with star connected compensators on the high voltage side, the following formula applies:

$$\begin{aligned} \text{Comp. Setting} &= \frac{50 (KV_L)(KV_H) R_C (\%Z)}{(KVA) R_V} \\ &= \frac{5ZR_C (KV_H)}{R_V (KV_L)} \text{ volts (7)} \end{aligned}$$

This formula will give the resistive and reactive compensator settings by substituting either $\%R$ or R and $\%X$ or X in place of $\%Z$ or Z . If the calculated tap setting does not agree with any combination of values on the compensator, the next lower tap should be used to avoid over compensation.

In the case of the Star-Delta connected power transformer, an auxiliary potential transformer is required as per Fig. 5.

CASE III Star-Delta Connected Power Transformer Compensator Current Transformer Outside Delta (Figs. 5 and 12).

It should be noted that with the current transformers connected outside the delta, single phase-to-ground faults will give incorrect line-to-ground voltage due to the

circulating current in the delta which does not pass thru the current transformers. This is not important in applying relays for phase fault protection. The voltage appearing across the terminals L and T of the compensators is proportional to the difference between two equivalent power transformer current. The delta voltage AB is obtained from the voltages of the two transformers A and B, and it must be compensated by the drop in each of the two transformers. The star-delta auxiliary potential transformers provide voltages corresponding to the high tension voltages in phase position, but uncompensated in magnitude. Current A" feeding the A compensator is related to $I_A = I_C$ and current B" feeding B compensator is related to $I_B = I_A$. The compensators add the two voltages appearing across their terminals. Since the voltage path from A' to B' traverses the L and T terminals of the two compensators in opposite directions, the total compensated voltage is proportional to $3 Z I_A$ if $I_A + I_B + I_C$ is equal to zero. If $I_A + I_B + I_C$ is not equal to zero, there is a circulating current in the delta which will cause equal and opposite drops in transformers A and B so the delta voltage is still correctly compensated. Combining these compensator voltages with the low tension star voltages as shown, gives the compensated delta voltages for the relays. Thus, the compensated relay voltages from the vector diagrams are $E_{A'C}$, $E_{C'B}$, or $E_{B'A}$. This method of compensation should be used only when delta relay voltages are required as the voltages A', B' or C' to ground are not the true phase-to-ground compensated voltages as they are in Figs. 4 and 6.

The compensators are connected in star and receive current as defined in equation 1. However, as shown in the vector diagram, this connection gives a delta voltage compensation. Consequently, the voltage drop across the bank at unit current in terms of the delta relay voltage is:

$$\frac{V_L}{R_V} \times \frac{\%Z}{100} \text{ volts (8)}$$

In terms of 5 amperes in the primary compensator windings, $\frac{5}{I_C} \times \frac{V_L}{R_V} \times \frac{\%Z}{100}$ gives the setting. Therefore, for star-delta power

TYPE KX COMPENSATOR

transformers with star connected compensators connected outside the low voltage delta winding, the following formula applies:

$$\text{Comp. Setting} = \frac{50\sqrt{3} (KV_L)^2 R_C (\%Z)}{(KVA) R_V} = \frac{5\sqrt{3} Z R_C}{R_V} \text{ volts} \quad (9)$$

This formula will give the resistive and reactive compensator settings by substituting either $\%R$ or R and $\%X$ or X in place of $\%Z$ or Z . If the calculated tap setting does not agree with any combination of values on the compensator, the next lower tap should be used to avoid over compensation.

CASE IV Star-Delta Connected Power Transformer-Compensator Current Transformers Inside Delta (Figs. 6 & 11).
The compensator current equals:

$$I_C = \frac{KVA}{3 (KV_L) R_C} \text{ amperes} \quad (10)$$

The compensated voltages are in phase with the star voltages on the high voltage side. Thus the voltage drop across the bank at unit current in terms of the star relay voltage is:

$$\frac{V_L}{\sqrt{3} R_V} \times \frac{\%Z}{100} \text{ volts} \quad (11)$$

and in terms of 5 amperes:

$$\frac{5}{I_C} \times \frac{V_L}{\sqrt{3} R_V} \times \frac{\%Z}{100} \text{ volts} \quad (12)$$

Therefore, for star-delta power transformers with star connected compensators connected inside the low voltage delta winding, for the following formula applies:

$$\text{Comp. Setting} = \frac{50\sqrt{3} (KV_L)^2 R_C (\%Z)}{(KVA) R_V} = \frac{5\sqrt{3} Z R_C}{R_V} \text{ volts} \quad (13)$$

This formula will give the resistive and reactive compensator settings by substituting either $\%R$ or R and $\%X$ or X in place of $\%Z$ or Z . If the calculated tap setting does not agree with any combination of values on the compensator, the next lower tap should be used to avoid over compensation.

It is interesting to note that formula 13 is equivalent to formula 9.

EXAMPLE FOR SETTING COMPENSATORS ON A TWO WINDING BANK

The following actual installation will serve to illustrate the use the formulas in setting the Type KX Compensator. The transformer bank is a 12,500 KVA Bank connected star on the 110 KV side and delta on the 13.2 KV side. Open Delta potential transformers are connected to the 13.2 KV side and an auxiliary delta star potential transformer is available to provide the correct 110 volt relay potential for distance relaying. The compensators are to be connected to 75/5 current transformers in the 110 KV winding. The bank reactance is 7.5% and the copper loss is 35,000 watts.

This connection corresponds to CASE II. The reactance setting is per formula 7.

$$X \text{ Setting} = \frac{50 \times 13.2 \times 110 \times 15 \times 7.5}{12,500 \times 120} = 5.45 \text{ volts}$$

Set the reactance dials on 4.57 and .70 taps on S#45852 compensators.

The transformer bank resistance is found from the equation $I^2 R = \text{watts}$.

$$I = \frac{12,500}{\sqrt{3} \times 13.2} = 546 \text{ amperes}$$

$$R = \frac{35,000}{546^2} = .117 \text{ ohms at } 13.2 \text{ KV}$$

The resistance setting is per formula 7.

$$R \text{ Setting} = \frac{5 \times .117 \times 15 \times 110}{120 \times 13.2} = .61 \text{ volts}$$

Set the resistance dials on 0 and .50 taps.

CASE V Three Winding Transformer Banks with Power Sources connected to the low voltage and tertiary windings. The voltage drop across the three winding transformer banks as shown in Fig. 7 is:

$$I_1 Z_L + (I_1 + I_2) Z_H \text{ volts} \quad (14)$$

Thus two sets of compensators are required; one on the high voltage winding set for Z_H and

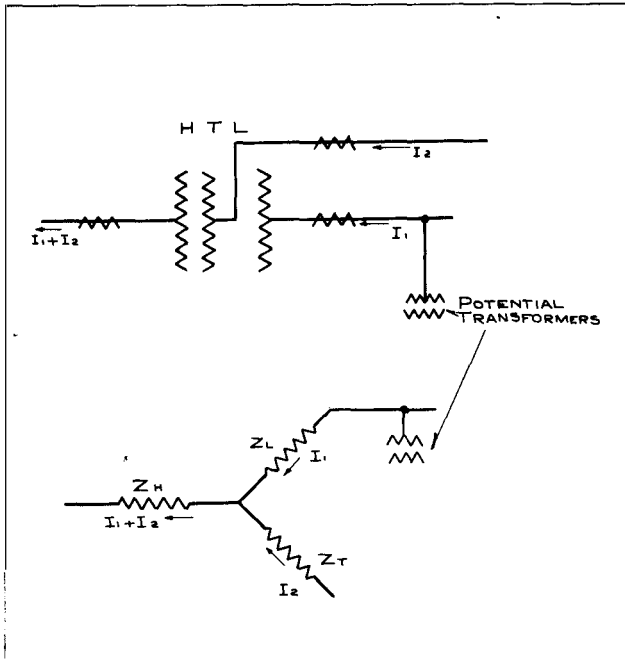

Fig. 7—General Case For The Application of The Type KX Compensators Thru a Three Winding Power Transformer Bank With Fault Power Feedback From Two Windings.

one on the low voltage set for Z_L .

If current transformers are available for compensation on the low voltage and tertiary windings, then equation (14) can be rewritten:

$$I_1 (Z_L + Z_H) + I_2 Z_H \text{ volts} \quad (15)$$

This shows that the compensator receiving I_1 on the low voltage side must be set for $Z_L + Z_H$ ohms, and the compensator receiving I_2 on the tertiary must be set for Z_H ohms.

The impedances of a three winding transformer are usually given as the impedances between each pair of the three windings in turn, and it is necessary to convert these impedance values into equivalent star impedances Z_H , Z_L and Z_T for use in setting the compensators for three winding bank. In Fig. 7, the impedance between the H and L windings is Z_{HL} ; between H and T windings is Z_{HT} ; and between T and L, Z_{TL} . Then the equivalent star impedances are given by the following equations:

$$Z_H = 1/2 (Z_{HL} + Z_{HT} - Z_{LT}) \quad (16)$$

$$Z_L = 1/2 (Z_{HL} + Z_{LT} - Z_{HT}) \quad (17)$$

$$Z_T = 1/2 (Z_{HT} + Z_{LT} - Z_{HL}) \quad (18)$$

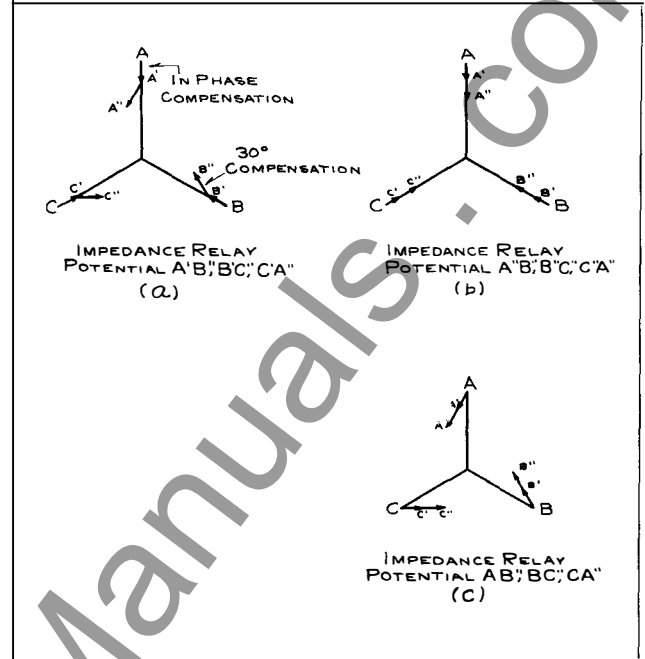

Fig. 8—Compensation Vector Diagrams For Three Winding Power Transformer Banks.

A. Star (H) - Star (L) - Delta (T) Bank. Current transformers on high (H) and low (L) tension windings:

Two sets of compensators are required in line with equation (14). The setting for the compensators using the low tension current transformers is the same as equation 6 except Z is Z_L and for the compensators using high tension current is the same as equation 7 except Z is Z_H . The two compensator voltages are shown in Fig. 8b. The schematic connections can be easily derived from Fig. 4.

B. Star (H) - Star (L) - Delta (T) Bank. Current transformers on low (L), winding and inside the delta tertiary (T) windings:

Two sets of compensators are required in line with equation (15). The two compensator voltages are shown in the vector diagram of Fig. 8b. The schematic connections can be derived easily from Figs. 4 and 6. The setting for the compensators using the low tension current transformers is the same as equation 6 except Z is $Z_L + Z_H$. The setting for the compensators using the tertiary current transformers connected inside the

TYPE KX COMPENSATOR

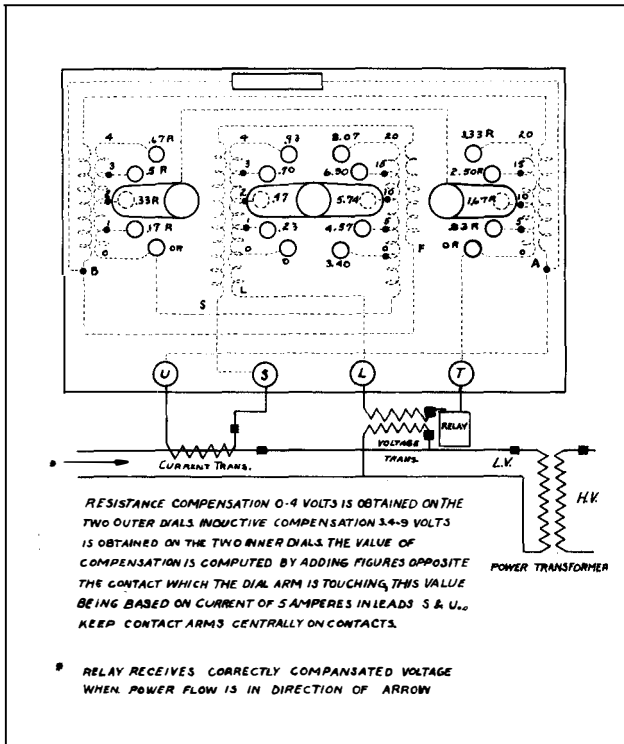

Fig. 9—Internal Connections of S#458551 Type KX Compensator.

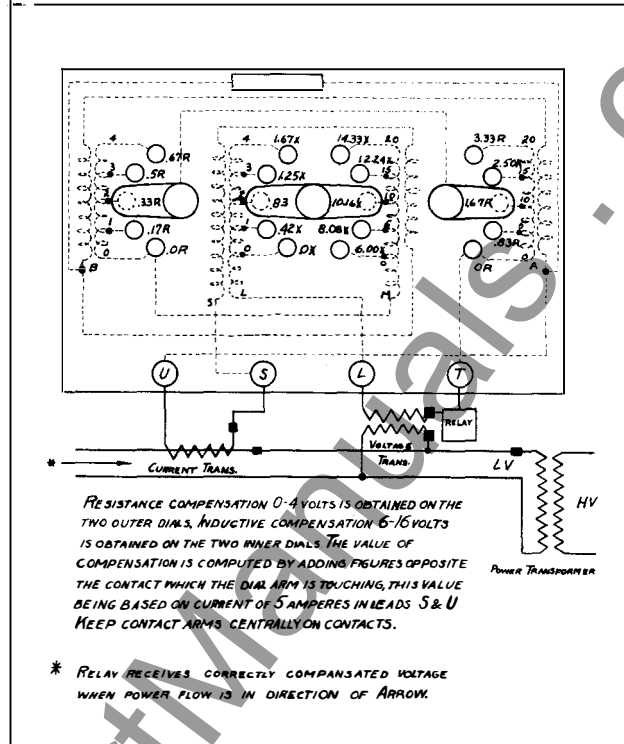

Fig. 10—Internal Connections of S#458552 Type KX Compensator.

delta is as follows: The compensator current is:

$$I = \frac{KVA}{3(KV_T)R_C} \text{ amperes} \quad (19)$$

The compensated voltages are in phase with the star voltages on the high side. Thus the voltage drop across the bank at unit current in terms of the star voltage is:

$$\frac{V_L}{\sqrt{3}R_V} \times \frac{\%Z_H}{100} \text{ volts} \quad (20)$$

and in terms of 5 amperes:

$$\frac{5}{I_C} \times \frac{V_L}{\sqrt{3}R_V} \times \frac{\%Z_H}{100} \text{ volts} \quad (21)$$

Therefore, the setting is:

$$\text{Comp. Setting} = \frac{50\sqrt{3}(KV_T)(KV_L)R_C(\%Z_H)}{(KVA)R_V} \quad (22)$$

$$= \frac{5\sqrt{3}R_C Z_H (KV_T)}{R_V (KV_L)} \text{ volts}$$

This formula will give the resistive and reactive compensator settings by substituting either $\%R$ or R and $\%X$ or X in place of $\%Z$ or Z . If the calculated tap setting does not agree with any combination of values on the compensator, the next lower tap should be used to avoid over compensation.

C. Star (H) - Star (L) - Delta (T) - Bank. Current transformers in low (L) winding and outside the delta (T) winding. Two sets of compensators are required in line with equation (15). The two compensator voltages are shown in Fig. 8A. The schematic connections can be derived easily from Figs. 4 and 5. The setting for the compensators using the low tension current transformers is the same as equation 6 except Z is $Z_L + Z_H$. The setting for the compensators using the tertiary current transformers connected outside the delta is the same as equation (22) by comparison of the equations (9) and (13).

D. Star (H) - Delta (L) - Delta (T) Bank. Current Transformers on low (L) winding inside delta and on high (H) winding.

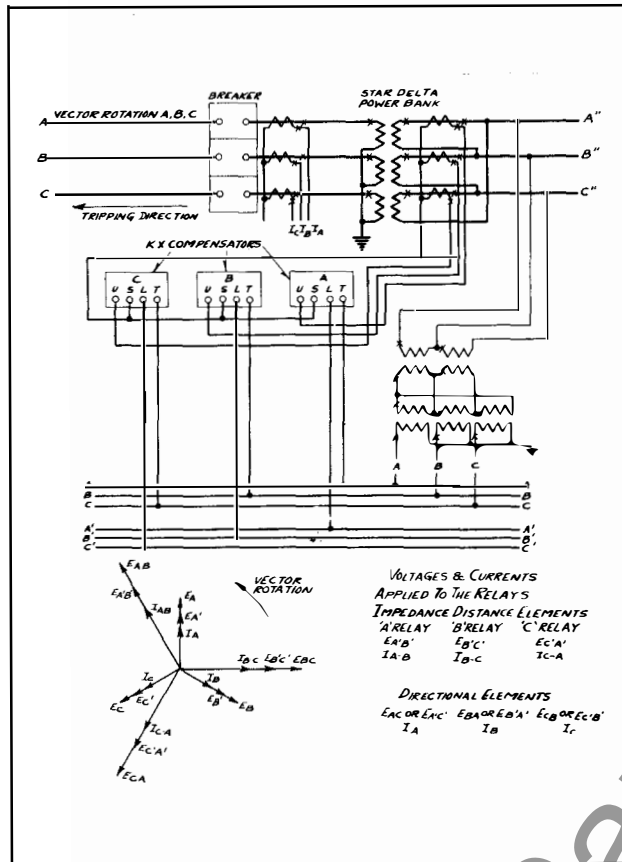

Fig. 11—External Connections of The Type KX Compensators Connected to Secondary Current Transformers Inside the Delta of a Star-Delta Bank.

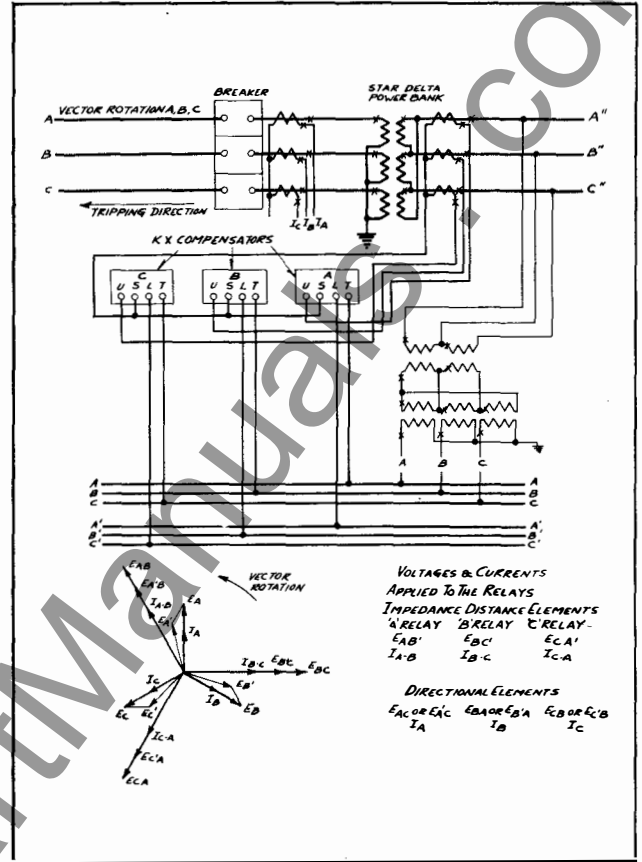

Fig. 12—External Connections of The Type KX Compensators Connected to Secondary Current Transformers Outside the Delta of a Star-Delta Bank.

Two sets of compensators are required in line with equation (14). The two compensator voltages are shown in Fig. 8b. The schematic connections can be easily derived from Figs. 4 and 6. The setting for the compensators using the high tension current transformers is the same as equation 7 except Z is Z_H . The setting for the compensator using current transformers inside the low tension delta winding is the same as equation 13 except $Z = Z_L$.

A summary of the compensator settings for various combinations of three winding transformer and associated current transformers is shown in Table I. This shows the more common connections some of which are discussed above, and some that are not as they can easily be derived from the foregoing.

EXAMPLE FOR SETTING COMPENSATORS ON A THREE WINDING BANK

It is desired to set Type KX Compensators using low (300/5 outside delta) and high winding (150/5) current transformers on a 110 KV star, 33 KV delta, 13.2 KV delta three winding transformer with a source of power connected to the low and tertiary windings. The potential transformers are available on the 33 KV winding and relays are to protect the 110 KV line. The percent impedance values on 20,000 KVA base are:

$$\begin{aligned} Z_{HL} &= 1.2 + j8 \\ Z_{HT} &= 2.0 + j16 \\ Z_{LT} &= 2.0 + j12 \end{aligned}$$

From equations 16, 17 and 18.

$$\begin{aligned} Z_H &= 0.6 + j6 \\ Z_L &= 0.6 + j2 \\ Z_T &= 1.4 + j10 \end{aligned}$$

Two sets of compensators are required, and the

TYPE KX COMPENSATOR

settings are per Table I. The compensators connected to the current transformers on the 110 KV side will be set per equation 7, using Z_H , or

$$X \text{ Setting} = \frac{50 \times 33 \times 110 \times 30 \times 6}{20,000 \times 300} = 5.45 \text{ volts}$$

Set the reactance dials on 4.57 and 93 taps on S#458552 Compensators.

$$R \text{ Setting} = \frac{50 \times 33 \times 110 \times 30 \times 0.6}{20,000 \times 300} = .54 \text{ volts}$$

Set the resistance dials on 0 and .50 taps on the compensators.

The second set of compensators connected to the current transformers outside the 33 KV delta winding will be according to equation 9 using Z_L , or

$$X \text{ Setting} = \frac{50 \sqrt{3} \times 33 \times 33 \times 60 \times 2}{20,000 \times 300} = 1.88 \text{ volts}$$

Set the reactance dials on 0 and 1.67 taps on S#458551 compensators.

$$R \text{ Setting} = \frac{50 \times 33 \times 33 \times 60 \times .6}{20,000 \times 300} = .57 \text{ volts}$$

Set the resistance dials on 0 and .50 taps on the compensators.

INSTALLATION

The Type KX Compensators are mounted in the

case of Fig. 13 and are intended for indoor mountings. Since they are static equipment and do not require adjustment after installation, the compensator can be mounted behind the switchboard on suitable brackets.

The external connections for two typical cases are shown in Figs. 11 and 12. After the final setting have been made, the dial arms should be securely fastened.

ADJUSTMENTS AND MAINTENANCE

The proper adjustments to insure correct operation have been made at the factory and should not be disturbed by the customer.

The Type KX Compensators require almost no maintenance. An occasional inspection is recommended to see that no excessive corrosion has taken place or terminal screws become loose.

RENEWAL PARTS

Repair work can be done most satisfactorily at the factory. However, interchangeable parts can be furnished to the customers who are equipped for doing repair work. When ordering parts, always give the complete name-plate data.

ENERGY REQUIREMENTS

The burden of either style compensator is 50 volt-amperes, at 5 amperes, 60 cycles.

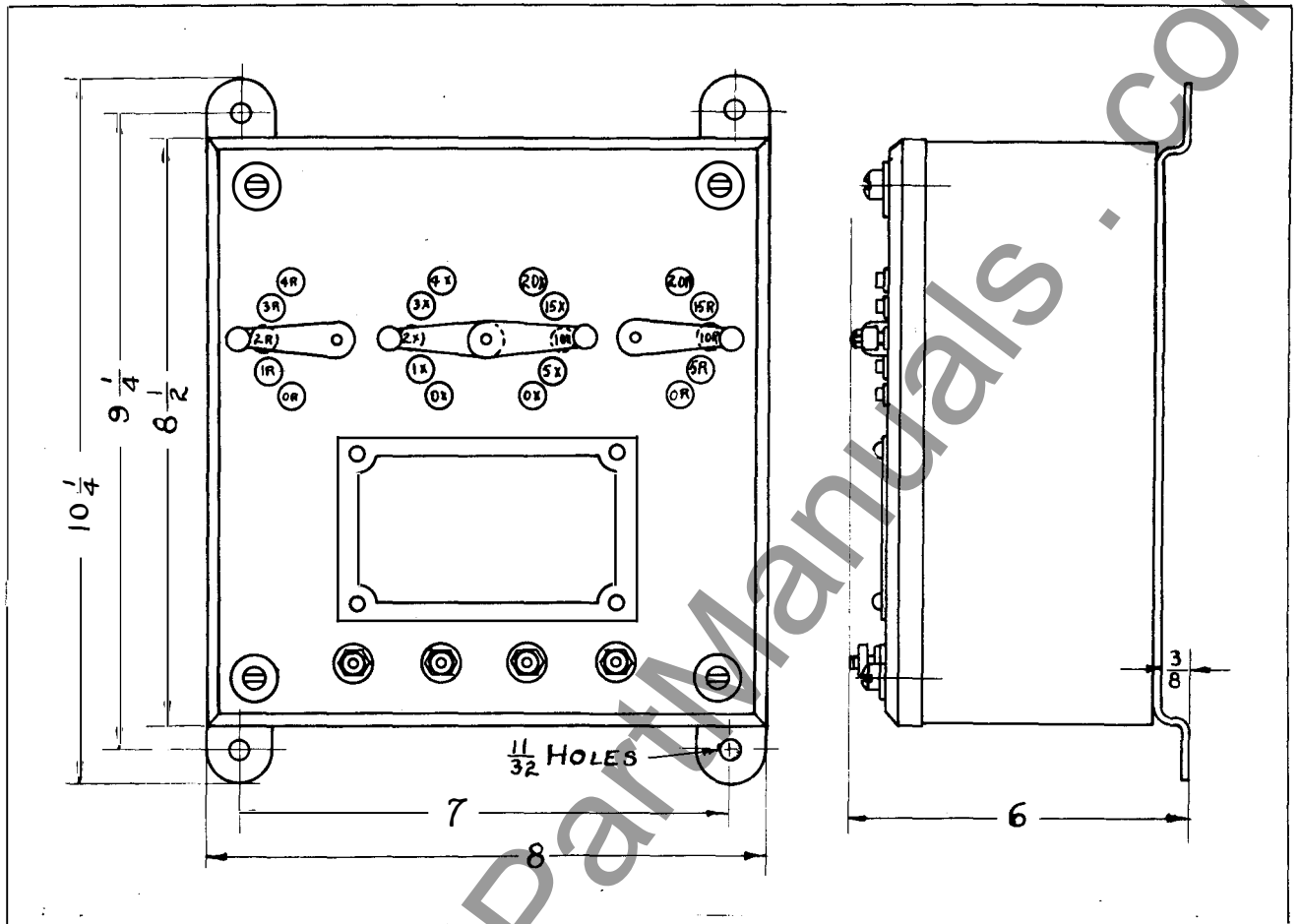

Fig. 13—Outline and Drilling Plan of The Type KX Compensator.

TABLE I

KX Compensators for Three Winding Transformer Banks

Using potential transformers on the low voltage (L) winding and compensating for distance relay protecting line connected to high voltage (H) winding. All current transformers and compensators connected in star.

H High Voltage Winding	L Low Voltage Winding	T Tertiary Winding	Vector Reference Figure	Set Compensators for a value of Z using Equation:					
				H Winding Z		L Winding LZ		T Winding Z	
				Value	Equation	Value	Equation	Value	Equation
Y*	Y*	Δ	8b	Z _H	7	Z _L	6		
Y	Y*	Δ * _i	8b			Z _L + Z _H	6	Z _H	22
Y	Y*	Δ * _o	8a			Z _L + Z _H	6	Z _H	22
Y*	Δ * _i	Δ	8b	Z _H	7	Z _L	13		
Y*	Δ * _o	Δ	8b	Z _H	7	Z _L	9		
Y	Δ * _i	Δ * _i	8b			Z _L + Z _H	13	Z _H	22
Y	Δ * _o	Δ * _o	8c			Z _L + Z _H	9	Z _H	22
Y	Δ * _o	Δ * _i	8a			Z _L + Z _H	9	Z _H	22

The formulas will give the resistive and reactive compensator settings by substituting either %R or R and %X or X in place of %Z or Z. If the calculated tap setting does not agree with any combination of values on the compensator, the next lower tap should be used to avoid over compensation.

- * Compensator current transformer location.
- i Current transformers inside delta.
- o Current transformers outside delta.



WESTINGHOUSE ELECTRIC CORPORATION
METER DIVISION

NEWARK, N.J.

Printed in U.S.A.

Westinghouse

TYPE KX COMPENSATOR

INSTRUCTIONS

APPLICATION

The Type KX compensator provides a secondary voltage which is proportional in phase and magnitude to the voltage drop thru a power transformer bank. Thus, the compensator with its associated current and potential transformers make possible the reliable measurement of transmission line relay potential from bus potential transformers. This is often economically advantageous in the application of impedance or distance type relays where the impedance of the power transformer bank is not included as a part of the transmission line and where potential transformers are not available on the transmission lines. In the usual case distance type relays are desired to protect a high-voltage transmission line where only low voltage potential transformers are available.

Distance type relays such as the types HZ, HCZ, CZ and HY relays view electrical distance (impedance and reactance) from the point on the system where the relay potential is measured. If this potential is taken from the low voltage bus and if fault power flows thru the transformer bank for high voltage line faults, then the voltage of the low voltage potential transformers for these faults will be relatively higher than the respective voltage on the high voltage potential transformer by the impedance drop thru the transformer bank. To the distance relay set only on the basis of the transmission line impedance and using low voltage potential, the line fault would appear to be further away from the high voltage side of the bank than it actually is. However, if there is no power source connected to the low voltage bus, then there is no fault power fed thru the bank, and the low and high voltage potential are essentially equivalent. In this last case the low voltage potential transformers may be used for distance relays without type KX compensators.

CONSTRUCTION AND OPERATION

The Type KX compensator consists of a reactance transformer and transformer connected with both their primary and secondary windings in series as shown in figure 1. The reactance transformer contains air gaps in its magnetic circuit so that the magnetizing current is large and consequently the voltage induced in its secondary winding is approximately 90° out of phase with the primary current. This element provides reactive compensation.

The transformer which supplies the resistive compensation has its magnetic circuit designed to give a low magnetizing current. A resistor is connected across the primary windings causing the transformer primary current to

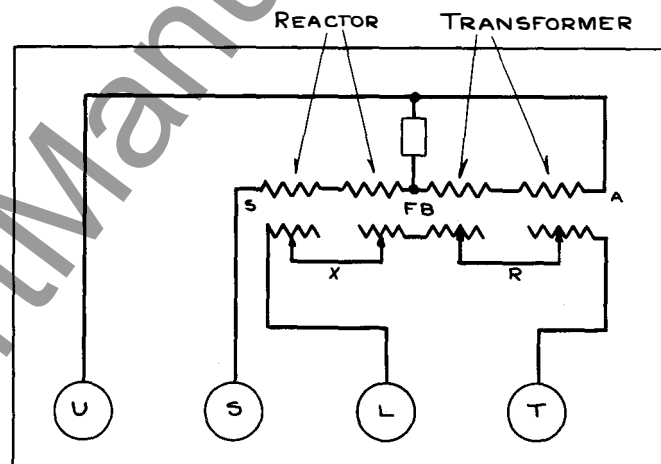

Figure 1
Schematic Connection of the Type KX Compensator.

lag the total input current. This combination shifts the secondary induced voltage until it is approximately in phase with the total input current.

The Type KX compensator is energized from current transformers giving a current proportional to the current thru the power transformer. It is adjustable so that a voltage may be produced by the current proportional to and in phase with the voltage drop thru the power transformer. By properly combining this voltage drop with the low tension voltage, a voltage exactly proportional to and in phase with the desired high tension voltage is obtained. This latter voltage is applied to the distance relay potential coils.

The terminals U and S of the schematic wiring figure 1 are the current terminals and the terminals L and T are the voltage terminals. By properly adjusting the R and X values the voltage produced across terminals L and T by the current flowing between U and S will be proportional to and in phase with the drop in the transformer. Under these conditions the ratio between R and X in the compensator will be the same as the ratio between R and X in the power transformer.

RETURN
TO
ENGINEERING DIVISION
BUFFALO OFFICE
WESTINGHOUSE ELEC. & MFG. CO.

Superseded by I.L. 41-540A.
Nov 1948

TYPE KX COMPENSATOR

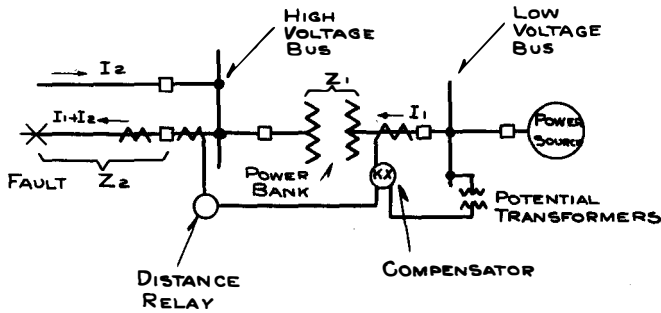

Figure 2

General Case For The Application of The Type KX Compensator Thru One Power Transformer Bank.

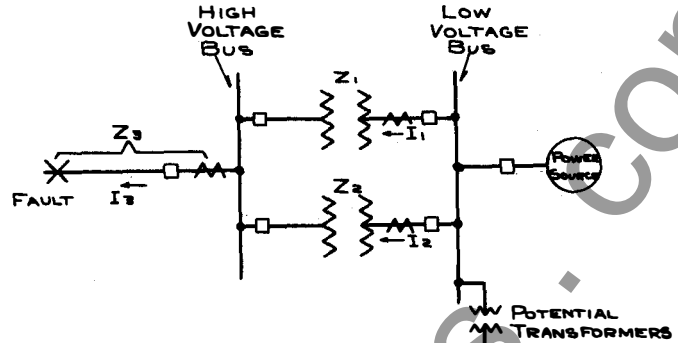

Figure 3

General Case For The Application of The Type KX Compensator Thru Two or More Power Transformer Banks.

CHARACTERISTICS

Two ranges of the Type KX Compensator are available, and are:

Style #	Compensation Range (Volt at 5 amps.)		Max. Secondary Impedance (Ohms)
	Resistive	Inductive	
458551	0-4	3,4-9	5
458552	0-4	6-16	9

The resistance and reactance drop produced in the compensator for each setting is marked on the compensator as shown in figures 9 and 10.

These values are based on the assumption that 5 amperes are flowing thru the primary of the compensator. Thus if the resistance and reactance drops in the power transformer are known, the current thru the compensator under full load conditions may be calculated and from this the proper setting computed. This is covered under Settings.

The polarity of the Type KX compensator is such that at the instant current is flowing in at terminal S and out at U, the terminal L is positive with respect to terminal T.

The secondary windings of the compensator are connected in series with the low voltage potential transformer secondary winding and the relays. Since the compensator secondary windings necessarily have some impedance, the voltage across the relay coils will be slightly less than the potential transformer secondary voltage at zero compensation. With a fixed relay burden this compensator impedance voltage drop is always a constant percentage of the total voltage. This percentage for one set of either the Type HZ, CZ or HCZ relays is less than 2.5% with the maximum compensator setting of 9 ohms and the minimum relay burden. If the potential burden imposed on the potential transformers and compensators is increased giving an appreciable drop across the compensator, the distance relay can still be set accurately by taking into account the reduced relay voltage in the relay tap formula. For example in setting the Type HZ impedance relay the formula is:

$$TS = \frac{10 Z R_C}{R_v}$$

Now if the compensator voltage drop is 10% of the total drop so that the relay only receives 90% voltage, then the formula can be modified by increasing the potential transformer ratio thus,

$$TS = \frac{10 Z R_C}{1.1 R_v}$$

CONNECTIONS AND SETTINGS

The general installation requiring the Type KX compensators is shown schematically in figure 2. The distance relay protecting the high voltage line should respond only to the impedance Z_2 which would be the case if the current for the relay is taken from current transformers in the location shown and if the potential transformers measured the high voltage bus potential. But with low voltage potential transformers the relay voltage is increased by the drop $I_1 Z_1$ thru the power transformer bank. Therefore the Type KX Compensators are required and should be connected to receive I_1 and set to produce a secondary voltage drop equal to $I_1 Z_1$.

Quite often there are two or more power banks connecting the high and low voltage busses together. The general case with two banks is shown in figure 3. The voltage drop between busses in this case is $I_1 Z_1 = I_2 Z_2$ so that only one set of compensators is necessary receiving either I_1 or I_2 current and set for the corresponding impedance Z_1 or Z_2 respectively. If the bank on which compensators are connected is removed from service, then an additional set of compensators or some switching arrangement if the bank impedances are equal must be used to provide proper relay potential.

There are a variety of connections and respective settings which can be made depending on the current transformer locations and the power bank connections. The most common of these for both two and three winding transformer banks will be considered. The three winding bank cases are the same as the two winding banks where fault power is not fed from one of the windings such as the tertiary winding. The following nomenclature will be used.

$\%R, \%X, \%Z$ * Resistance, reactance, and impedance respectively, of the power transformer bank in percent.

R, X, Z * Resistance, reactance, and impedance respectively, of the power transformer banks in ohms at the low voltage base V_L .

KVA KVA base of the values of $\%R, \%X$ and $\%Z$ above.

V_L Line to line voltage of the low voltage side of the bank where the relay potential transformers are available.

KV_L Line to line kilovolts of the low

*Subscripts H, L, and T represent equivalent star values of three winding transformers defined in equations 16, 17, and 18.

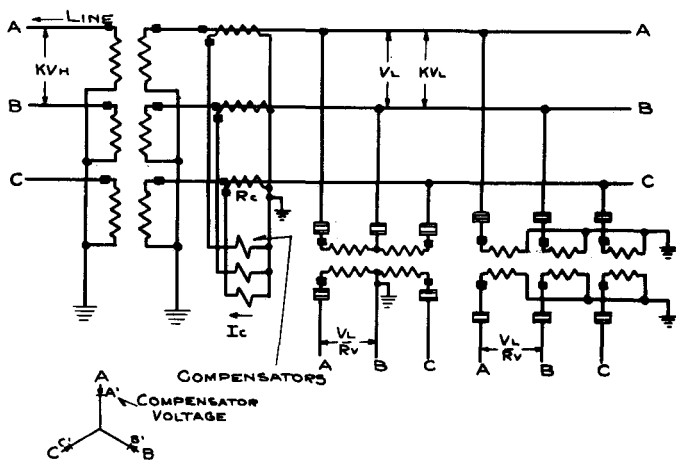

Figure 4
Schematic Compensation Diagram For Star-Star (Or Delta-Delta) Connected Power Transformer Banks.

- KV_H Voltage side of the transformer bank.
- KV_T Line to line kilovolts of the high voltage side of the transformer bank.
- KV_T Line to line kilovolts of the tertiary winding of a three winding transformer bank.
- R_V Potential transformer ratio.
- R_C Compensator current transformer ratio.
- I_C Current thru compensator primary windings in amperes.

CASE I Star-Star or Delta-Delta Connected Power Transformer -

In this case the compensators are connected in star to star-connected low voltage current transformers as shown in figure 4. Then the compensator current is,

$$I_C = \frac{(KVA)}{\sqrt{3} (KV_L) (R_C)} \text{ amperes} \quad (1)$$

By definition the percent impedance of the power transformer is the percent voltage drop across the bank at unit current. As shown in the vector diagram of figure 4 the compensating voltage is in phase with a star current. Therefore the voltage drop across the bank at unit current (in this case I_C) in terms of the star relay voltage is,

$$\frac{V_L}{\sqrt{3} (R_V)} \times \frac{(\%Z)}{100} \text{ volts} \quad (2)$$

The compensators are calibrated in volts when rated 5 amperes is flowing thru the primary. Then the compensator setting to give a voltage drop equivalent to the drop across the transformer bank is,

$$\begin{aligned} \frac{5}{I_C} \times \frac{V_L (\%Z)}{\sqrt{3} (R_V) (100)} \\ = \frac{5(V_L)(KV_L)(R_C)(\%Z)}{(KVA)(R_V)(100)} \end{aligned} \quad (3)$$

The same formula also may be easily derived from the ohm values of R, X, and Z instead of the more common percent values. The

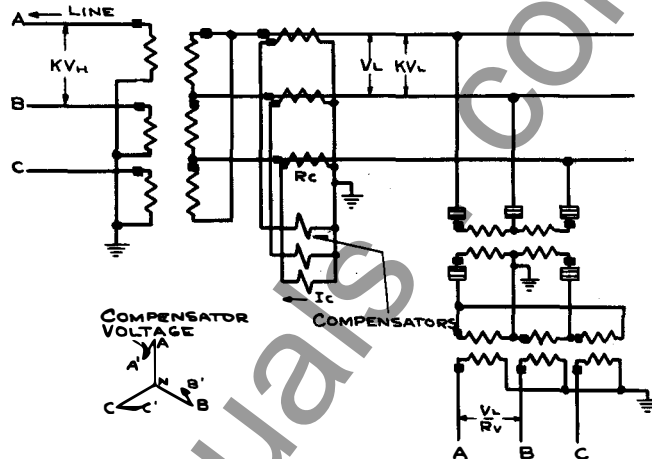

Figure 5
Schematic Compensation Diagram For Star-Delta Connected Power Transformer Banks With Current Transformers Outside Delta.

secondary voltage drop across the transformer bank is $\frac{IZ}{R_V}$ and the compensation primary current is $\frac{I}{R_C}$. Since the compensator is calibrated for 5 amperes in its primary, the compensator setting is,

$$\frac{5R_C}{I} \times \frac{IZ}{R_V} = \frac{5ZRC}{R_V} \text{ volts} \quad (4)$$

This is equal to the formula above since

$$Z \text{ Ohms} = \frac{10 (KV_L)^2 \times \%Z}{KVA} \quad (5)$$

Therefore for Star-Star or Delta-Delta connected power transformers with star connected compensators on the low voltage side, the following formula applies:

$$\text{Comp. Setting} = \frac{50 (KV_L)^2 R_C (\%Z)}{(KVA) R_V} = \frac{5ZRC}{R_V} \text{ volts} \quad (6)$$

This formula will give the resistive and reactive compensator settings by substituting either $\%R$ or R and $\%X$ or X in place of $\%Z$ or Z . If the calculated tap setting does not agree with any combination of values on the compensator, the next lower tap should be used to avoid over compensation.

CASE II Star-Star or Delta-Delta or Star-Delta Connected Power Transformer.

(Similar to figure 4 except compensator current transformers on high voltage side of bank.) This is the same as the case above except equation (1) is in terms of KV_H instead of KV_L . Therefore for star-star connected power transformers with star connected compensators on the high voltage side, the following formula applies:

$$\begin{aligned} \text{Comp. Setting} &= \frac{50(KV_L)(KV_H)R_C(\%Z)}{(KVA) R_V} \\ &= \frac{5ZRC(KV_H)}{R_V(KV_L)} \text{ volts} \end{aligned} \quad (7)$$

This formula will give the resistive and reactive compensator settings by substituting either $\%R$ or R and $\%X$ or X in place of $\%Z$

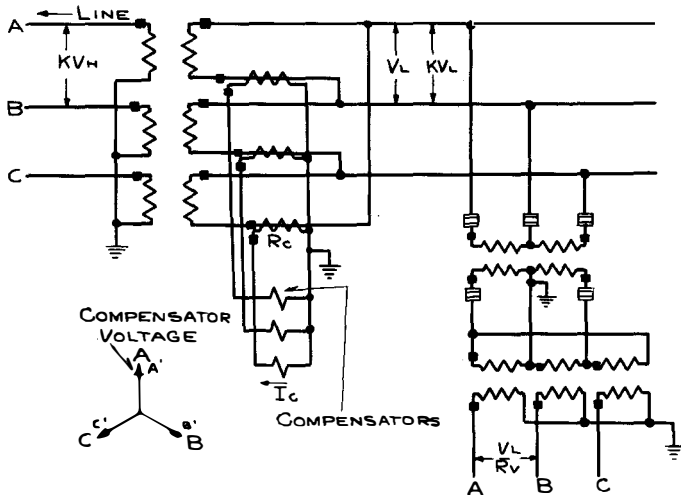

Figure 6

Schematic Compensation Diagram For Star-Delta Connected Power Transformer Banks With Current Transformers Inside Delta.

or Z. If the calculated tap setting does not agree with any combination of values on the compensator, the next lower tap should be used to avoid over compensation.

In the case of the Star-Delta connected power transformer, an auxiliary potential transformer is required as per figure 5.

CASE III Star-Delta connected power transformer Compensator Current Transformer Outside Delta (figure 5 & 12).

It should be noted that with the current transformers connected outside the delta, single phase-to-ground faults will give incorrect line-to-ground voltage due to the circulating current in the delta which does not pass thru the current transformers. This is not important in applying relays for phase fault protection. The voltage appearing across the terminals L and T of the compensators is proportional to the difference between two equivalent power transformer currents. The delta voltage AB is obtained from the voltages of the two transformers A and B, and it must be compensated by the drop in each of the two transformers. The star-delta auxiliary potential transformers provide voltages corresponding to the high tension voltages in phase position, but uncompensated in magnitude. Current A" feeding the A compensator is related to IA - IC and current B" feeding B compensator is related to IB - IA. The compensators add the two voltages appearing across their terminals. Since the voltage path from A' to B' traverses the L and T terminals of the two compensators in opposite directions, the total compensated voltage is proportional to 3 Z IA if IA + IB + IC is equal to zero. If IA + IB + IC is not equal to zero, there is a circulating current in the delta which will cause equal and opposite drops in transformers A and B so the delta voltage is still correctly compensated. Combining these compensator voltages with the low tension star voltages as shown, gives the compensated delta voltages for the relays. Thus, the compensated relay voltages from the vector diagrams are EA'C, EC'B, or EB'A. This method of compensation should be used only when delta relay voltages are required as the voltages A', B', or C' to ground are not the true phase-to-ground compensated voltages as they are in figures 4 and 6.

The compensators are connected in star and receive current as defined in equation 1. However as shown in the vector diagram this connection gives a delta voltage compensation. Consequently the voltage drop across the bank at unit current in terms of the delta relay voltage is:

$$\frac{V_L}{R_v} \times \frac{\%Z}{100} \quad \text{volts} \quad (8)$$

In terms of 5 amperes in the primary compensator windings, $\frac{5}{I_C} \times \frac{V_L}{R_v} \times \frac{\%Z}{100}$ gives the setting. Therefore for star-delta power transformers with star connected compensators connected outside the low voltage delta winding, the following formula applies:

$$\text{Comp. Setting} = \frac{50\sqrt{3} (KV_L)^2 R_C (\%Z)}{(KVA) R_v} = \frac{5\sqrt{3} Z R_C}{R_v} \quad \text{volts} \quad (9)$$

This formula will give the resistive and reactive compensator settings by substituting either %R or R and %X or X in place of %Z or Z. If the calculated tap setting does not agree with any combination of values on the compensator, the next lower tap should be used to avoid over compensation.

CASE IV Star-Delta Connected Power Transformer - Compensator Current Transformers Inside Delta (figure 6 & 11). The compensator current equals:

$$I_C = \frac{KVA}{3 (KV_L) R_C} \quad \text{amperes} \quad (10)$$

The compensated voltages are in phase with the star voltages on the high voltage side. Thus the voltage drop across the bank at unit current in terms of the star relay voltage is:

$$\frac{V_L}{\sqrt{3} R_v} \times \frac{\%Z}{100} \quad \text{volts} \quad (11)$$

and in terms of 5 amperes:

$$\frac{5}{I_C} \times \frac{V_L}{\sqrt{3} R_v} \times \frac{\%Z}{100} \quad \text{volts} \quad (12)$$

Therefore for star-delta power transformers with star connected compensators connected inside the low voltage delta winding, the following formula applies:

$$\text{Comp. Setting} = \frac{50\sqrt{3} (KV_L)^2 R_C (\%Z)}{(KVA) R_v} = \frac{5\sqrt{3} Z R_C}{R_v} \quad \text{volts} \quad (13)$$

This formula will give the resistive and reactive compensator settings by substituting either %R or R and %X or X in place of %Z or Z. If the calculated tap setting does not agree with any combination of values on the compensator, the next lower tap should be used to avoid over compensation.

It is interesting to note that formula 13 is equivalent to formula 9.

EXAMPLE FOR SETTING COMPENSATORS ON A TWO WINDING BANK

The following actual installation will serve to illustrate the use the formulas in setting the Type KX Compensator. The transformer bank is a 12,500 KVA Bank connected star on the 110 KV side and delta on the 13.2 KV side. Open Delta potential transformers are connected to the 13.2 KV side and an auxiliary delta star potential transformer is available to provide the correct .110 volt relay potential for distance relaying. The compensators are to be con-

TYPE KX COMPENSATOR

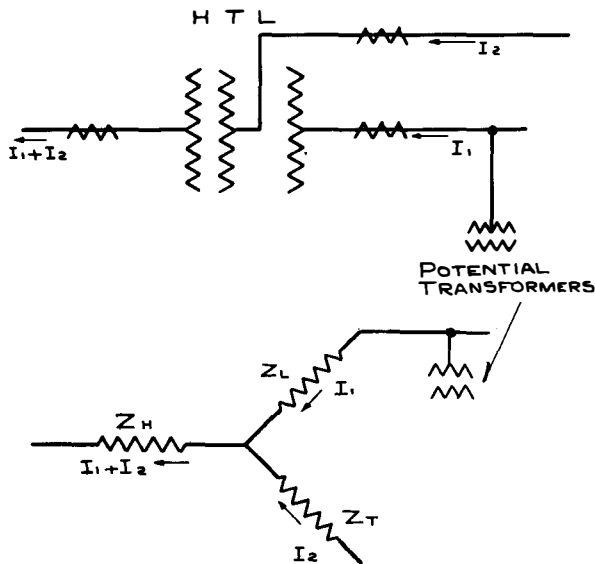

Figure 7

General Case For The Application of The Type KX Compensators Thru a Three Winding Power Transformer Bank With Fault Power Feedback From Two Windings.

ected to 75/5 current transformers in the 110KV winding. The bank reactance in 7.5% and the copper loss is 35,000 watts.

This connection corresponds to CASE II. The reactance setting is per formula 7.

$$X \text{ Setting} = \frac{50 \times 13.2 \times 110 \times 15 \times 7.5}{12,500 \times 120} = 5.45 \text{ volts}$$

Set the reactance dials on 4.57 and .70 taps on S#458552 compensators.

The transformer bank resistance is found from the equation $I^2R = \text{watts}$.

$$I = \frac{12,500}{\sqrt{3} \times 13.2} = 546 \text{ amperes}$$

$$R = \frac{35,000}{546^2} = .117 \text{ ohms at } 13.2 \text{ KV}$$

The resistance setting is per formula 7.

$$R \text{ Setting} = \frac{5 \times .117 \times 15 \times 110}{120 \times 13.2} = .61 \text{ volts}$$

Set the resistance dials on 0 and .50 taps.

CASE V Three Winding Transformer Banks with power Sources connected to the low voltage and tertiary windings. The voltage drop across the three winding transformer banks as shown in figure 7 is:

$$I_1 Z_L + (I_1 + I_2) Z_H \text{ volts} \quad (14)$$

Thus two sets of compensators are required; one on the high voltage winding set for Z_H and one on the low voltage set for Z_L .

If current transformers are available for compensation on the low voltage and tertiary windings, then equation (14) can be rewritten:

$$I_1 (Z_L + Z_H) + I_2 Z_H \text{ volts} \quad (15)$$

This shows that the compensator receiving I_1 on the low voltage side must be set for $Z_L + Z_H$ ohms, and the compensator receiving I_2 on the tertiary must be set for Z_H ohms.

The impedances of a three winding transformer are usually given as the impedances between each pair of the three windings in turn, and it is necessary to convert these impedance values into equivalent star impedances Z_H , Z_L and Z_T for use in setting the compensators for three winding bank. In figure 7, the impedance between the H and L windings is Z_{HL} ; between H and T windings is Z_{HT} ; and between T and L, Z_{TL} .

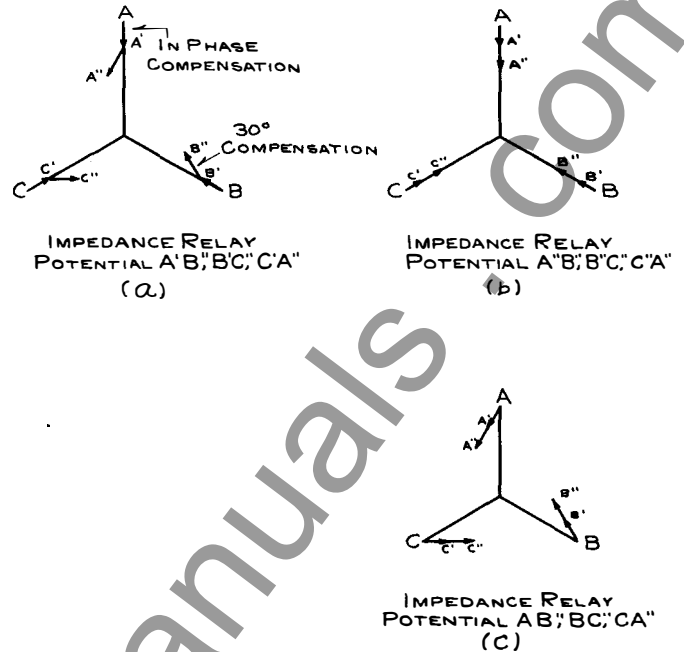

Figure 8

Compensation Vector Diagrams For Three Winding Power Transformer Banks.

Then the equivalent star impedances are given by the following equations:

$$Z_H = 1/2 (Z_{HL} + Z_{HT} - Z_{LT}) \quad (16)$$

$$Z_L = 1/2 (Z_{HL} + Z_{LT} - Z_{HT}) \quad (17)$$

$$Z_T = 1/2 (Z_{HT} + Z_{LT} - Z_{HL}) \quad (18)$$

A. Star (H) - Star (L) - Delta (T) Bank. Current transformers on high (H) and low (L) tension windings:

Two sets of compensators are required in line with equation (14). The setting for the compensators using the low tension current transformers is the same as equation 6 except Z is Z_L and for the compensators using high tension current is the same as equation 7 except Z is Z_H . The two compensator voltages are shown in figure 8b. The schematic connections can be easily derived from figure 4.

B. Star(H)-Star(L)-Delta(T) Bank. Current transformers on low (L), winding and inside the delta tertiary (T) windings:

Two sets of compensators are required in line with equation (15). The two compensator voltages are shown in the vector diagram of figure 8b. The schematic connections can be derived easily from figures 4 and 6. The setting for the compensators using the low tension current transformers is the same as equation 6 except Z is $Z_L + Z_H$. The setting for the compensators using the tertiary current transformers connected inside the delta is as follows: The compensator current is:

$$I = \frac{KVA}{\sqrt{3} (KV_T) R_C} \text{ amperes} \quad (19)$$

The compensated voltages are in phase with the star voltages on the high side. Thus the voltage drop across the bank at unit current in terms of the star voltage is:

$$\frac{V_L}{\sqrt{3} R_V} \times \frac{\%Z_H}{100} \text{ volts} \quad (20)$$

TYPE KX COMPENSATOR

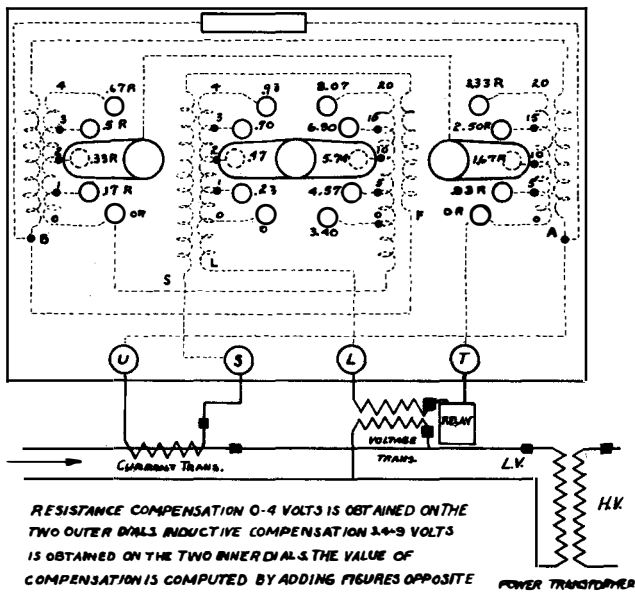

RESISTANCE COMPENSATION 0-4 VOLTS IS OBTAINED ON THE TWO OUTER DIALS. INDUCTIVE COMPENSATION 3.4-9 VOLTS IS OBTAINED ON THE TWO INNER DIALS. THE VALUE OF COMPENSATION IS COMPUTED BY ADDING FIGURES OPPOSITE THE CONTACT WHICH THE DIAL ARM IS TOUCHING, THIS VALUE BEING BASED ON CURRENT OF 5 AMPERES IN LEADS S & U. KEEP CONTACT ARMS CENTRALLY ON CONTACTS.

* RELAY RECEIVES CORRECTLY COMPENSATED VOLTAGE WHEN POWER FLOW IS IN DIRECTION OF ARROW

Figure 9

Internal Connections of S#458551 Type KX Compensator.

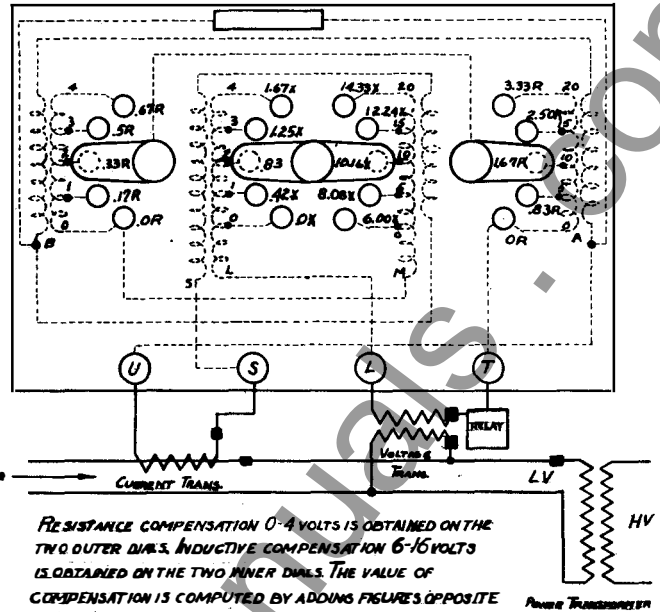

RESISTANCE COMPENSATION 0-4 VOLTS IS OBTAINED ON THE TWO OUTER DIALS. INDUCTIVE COMPENSATION 6-16 VOLTS IS OBTAINED ON THE TWO INNER DIALS. THE VALUE OF COMPENSATION IS COMPUTED BY ADDING FIGURES OPPOSITE THE CONTACT WHICH THE DIAL ARM IS TOUCHING, THIS VALUE BEING BASED ON CURRENT OF 5 AMPERES IN LEADS S & U. KEEP CONTACT ARMS CENTRALLY ON CONTACTS.

* RELAY RECEIVES CORRECTLY COMPENSATED VOLTAGE WHEN POWER FLOW IS IN DIRECTION OF ARROW

Figure 10

Internal Connections of S#458552 Type KX Compensator.

and in terms of 5 amperes:

$$\frac{5}{I_C} \times \frac{V_L}{\sqrt{3}R_V} \times \frac{\%Z_H}{100} \text{ volts} \quad (21)$$

Therefore the setting is:

$$\text{Comp. Setting} = \frac{5\sqrt{3}(KV_T)(KV_L)RC(\%Z_H)}{(KVA)R_V}$$

$$= \frac{5\sqrt{3}RCZ_H(KV_T)}{R_V(KV_L)} \text{ volts} \quad (22)$$

This formula will give the resistive and reactive compensator settings by substituting either %R or R and %X or X in place of %Z or Z. If the calculated tap setting does not agree with any combination of values on the compensator, the next lower tap should be used to avoid over compensation.

C. Star (H)-Star(L)-Delta (T) - Bank. Current transformers in low (L) winding and outside the delta (T) winding. Two sets of compensators are required in line with equation (15). The two compensator voltages are shown in figure

TABLE I

KX Compensators for Three Winding Transformer Banks

Using potential transformers on the low voltage (L) winding and compensating for distance relay protecting line connected to high voltage (H) winding. All current transformers and compensators connected in star.

H High Voltage Winding	L Low Voltage Winding	T Tertiary Winding	Vector Reference Figure	Set Compensators for a value of Z using Equation:					
				H Winding Z		L Winding LZ		T Winding Z	
				Value	Equation	Value	Equation	Value	Equation
Y*	Y*	Δ	8b	Z _H	7	Z _L	6	Z _H	22
Y	Y*	Δ *1	8b			Z _L + Z _H	6	Z _H	22
Y	Y*	Δ *°	8a			Z _L + Z _H	6	Z _H	22
Y*	Δ *1	Δ	8b	Z _H	7	Z _L	13		
Y*	Δ *°	Δ	8a	Z _H	7	Z _L	9		
Y	Δ *1	Δ *1	8b			Z _L + Z _H	13	Z _H	22
Y	Δ *°	Δ *°	8c			Z _L + Z _H	9	Z _H	22
Y	Δ *°	Δ *1	8a			Z _L + Z _H	9	Z _H	22

The formulas will give the resistive and reactive compensator settings by substituting either %R or R and %X or X in place of %Z or Z. If the calculated tap setting does not agree with any combination of values on the compensator, the next lower tap should be used to avoid over compensation.

*Compensator current transformer location.
iCurrent transformers inside delta.
°Current transformers outside delta.

TYPE KX COMPENSATOR

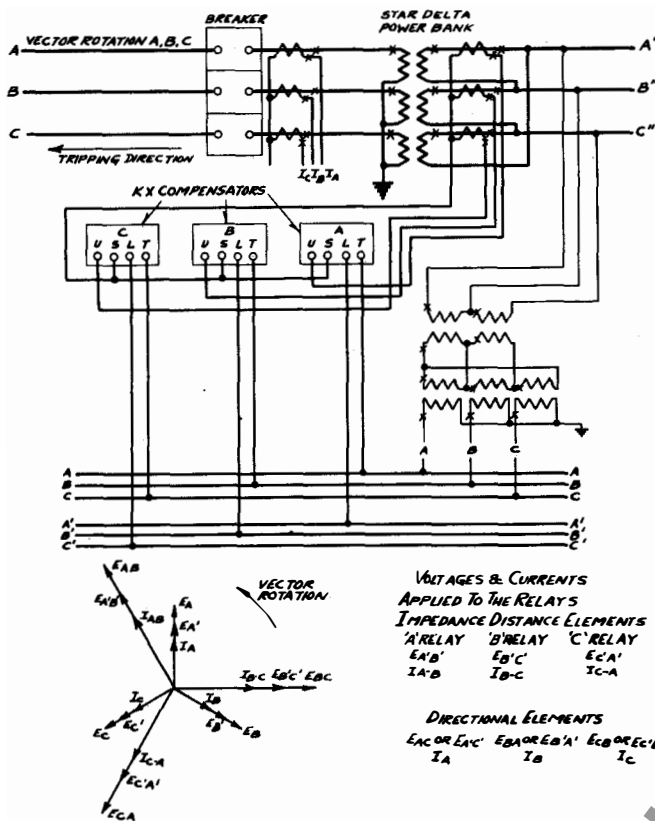

Figure 11

External Connections of the Type KX Compensators Connected to Secondary Current Transformers Inside the Delta of a Star-Delta Bank.

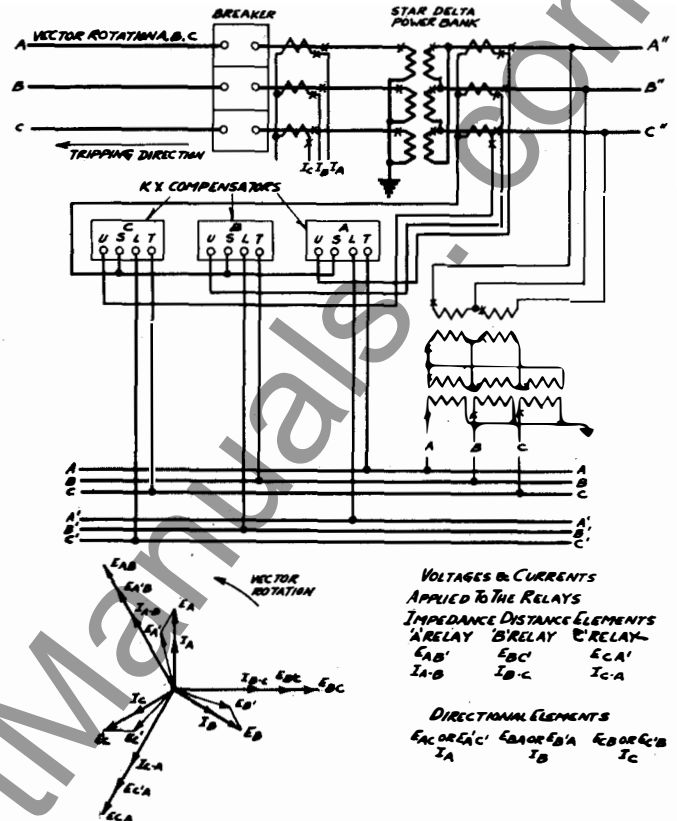

Figure 12

External Connections of the Type KX Compensators Connected to Secondary Current Transformers Outside the Delta of a Star-Delta Bank.

8A. The schematic connections can be derived easily from figures 4 and 5. The setting for the compensators using the low tension current transformers is the same as equation 6 except Z is $Z_L + Z_H$. The setting for the compensators using the tertiary current transformers connected outside the delta is the same as equation (22) by comparison of the equations (9) and (13).

D. Star(H)-Delta(L)-Delta(T) Bank. Current transformers on low (L) winding inside delta and on high (H) winding.

Two sets of compensators are required in line with equation (14). The two compensator voltages are shown in figure 8b. The schematic connections can be easily derived from figures 4 and 6. The setting for the compensators using the high tension current transformers is the same as equation 7 except Z is Z_H . The setting for the compensator using current transformers inside the low tension delta winding is the same as equation 13 except $Z = Z_L$.

A summary of the compensator settings for various combinations of three winding transformer and associated current transformers is shown in Table I. This shows the more common connections some of which are discussed above, and some that are not as they can easily be derived from the foregoing.

EXAMPLE FOR SETTING COMPENSATORS ON A THREE WINDING BANK

It is desired to set Type KX Compensators using low (300/5 outside delta) and high winding (150/5) current transformers on a 110KV star, 33KV delta, 13.2KV delta three winding transformer with a source of power connected to

the low and tertiary windings. The potential transformers are available on the 33KV winding and relays are to protect the 110KV line. The percent impedance values on 20,000 KVA base are:

$$\begin{aligned} Z_{HL} &= 1.2 + j8 \\ Z_{HT} &= 2.0 + j16 \\ Z_{LT} &= 2.0 + j12 \end{aligned}$$

From equations 16, 17, and 18.

$$\begin{aligned} Z_H &= 0.6 + j6 \\ Z_L &= 0.6 + j2 \\ Z_T &= 1.4 + j10 \end{aligned}$$

Two sets of compensators are required, and the settings are per Table I. The compensators connected to the current transformers on the 110KV side will be set per equation 7, using Z_H , or

$$X \text{ Setting} = \frac{50 \times 33 \times 110 \times 30 \times 6}{20,000 \times 300} = 5.45 \text{ volts}$$

Set the reactance dials on 4.57 and .93 taps on S#458552 Compensators.

$$R \text{ Setting} = \frac{50 \times 33 \times 110 \times 30 \times 0.6}{20,000 \times 300} = .54 \text{ volts}$$

Set the resistance dials on 0 and .50 taps on the compensators.

The second set of compensators connected to the current transformers outside the 33KV delta windings will be according to equation 9 using Z_L , or

$$X \text{ Setting} = \frac{50 \sqrt{3} \times 33 \times 33 \times 60 \times 2}{20,000 \times 300} = 1.88 \text{ volts}$$

Set the reactance dials on 0 and 1.67 taps on S#458551 compensators.

TYPE KX COMPENSATOR

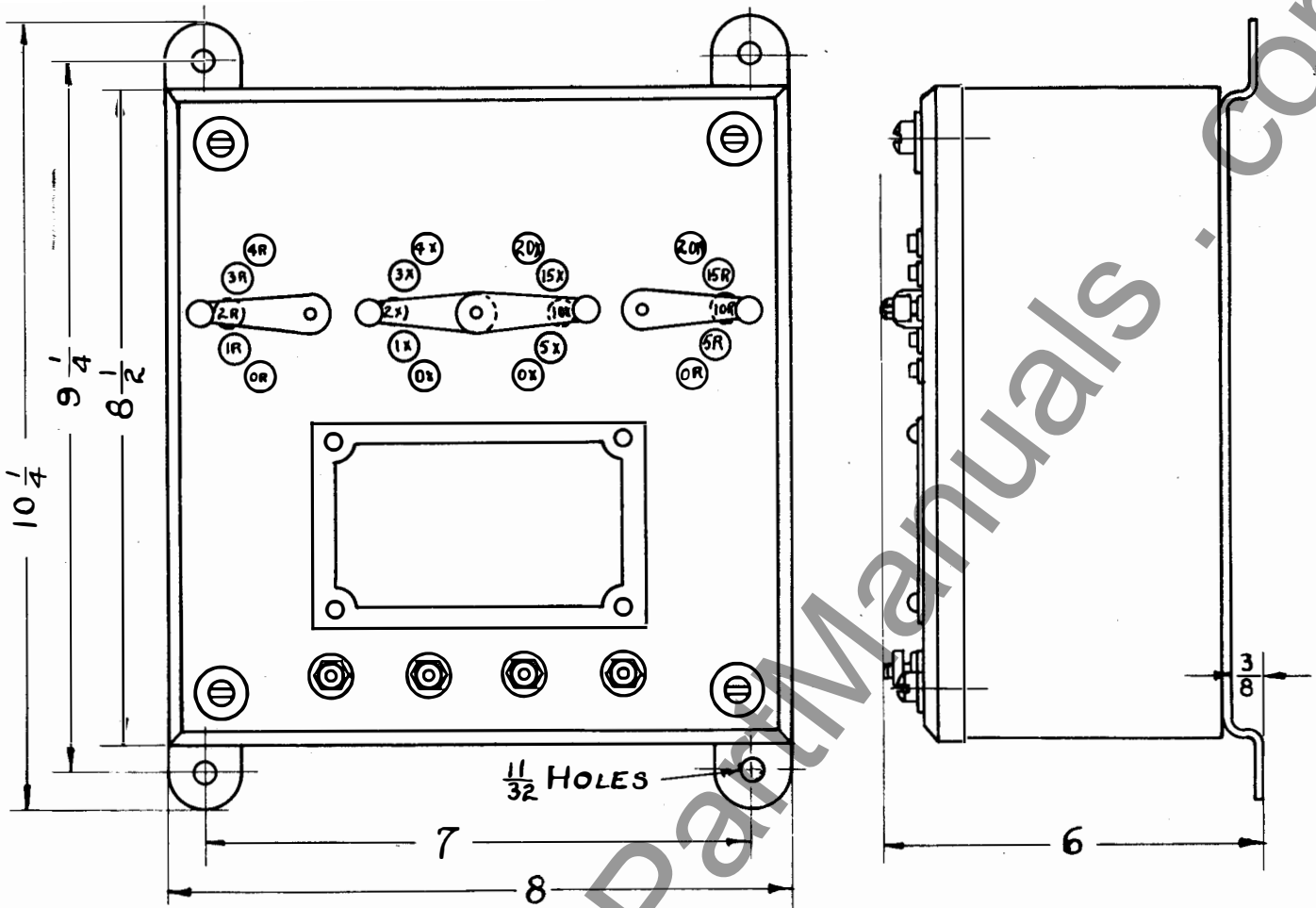

Figure 13
Outline and Drilling Plan of The Type KX Compensator.

$$R \text{ Setting} = \frac{50\sqrt{3} \times 33 \times 33 \times 60 \times .6}{20,000 \times 300} = .57 \text{ volts}$$

Set the resistance dials on 0 and .50 taps on the compensators.

INSTALLATION

The Type KX Compensators are mounted in the case of figure 13 and are intended for indoor mountings. Since they are static equipment and do not require adjustment after installation, the compensator can be mounted behind the switchboard on suitable brackets.

The external connections for two typical cases are shown in figures 11 and 12. After the final settings have been made, the dial arms should be securely fastened.

ADJUSTMENTS AND MAINTENANCE

The proper adjustments to insure cor-

rect operation have been made at the factory and should not be disturbed by the customer.

The Type KX Compensators require almost no maintenance. An occasional inspection is recommended to see that no excessive corrosion has taken place or terminal screws become loose.

RENEWAL PARTS

Repair work can be done most satisfactorily at the factory. However, interchangeable parts can be furnished to the customers who are equipped for doing repair work. When ordering parts, always give the complete nameplate data.

ENERGY REQUIREMENTS

The burden of either style compensator is 50 volt-amperes, at 5 amperes, 60 cycles.